

Regia



Instruction Manual

Part A: General Information

Part B: Operator and Technical Personnel

Part C: Care staff and residents



Part A: General Information

Regia (Standard) care bed

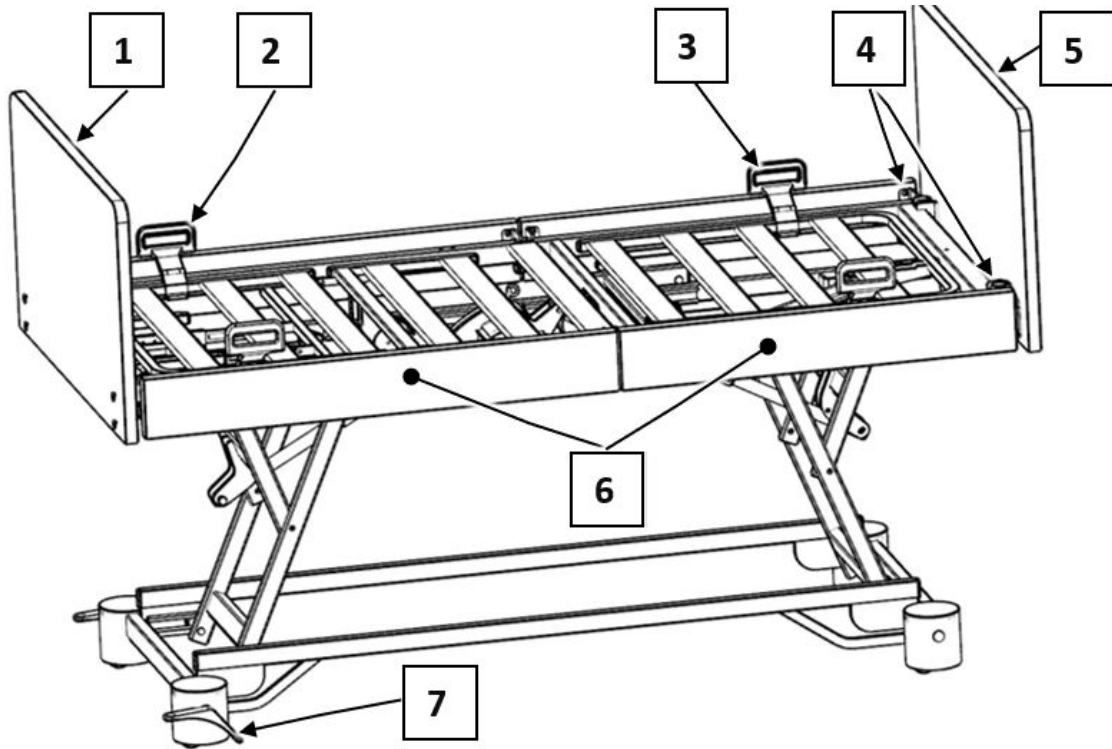

Regia care bed DSG (optional)

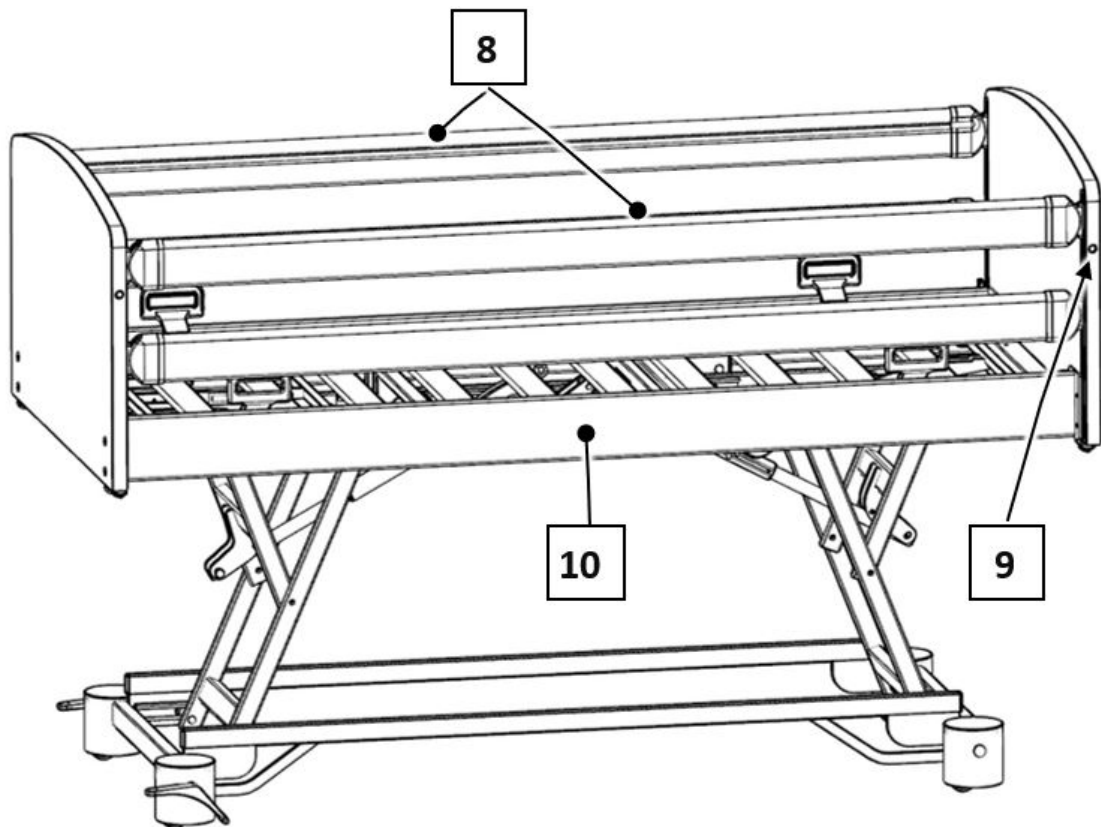

Regia care bed with telescopic safety sides (TSG) (optional equipment)

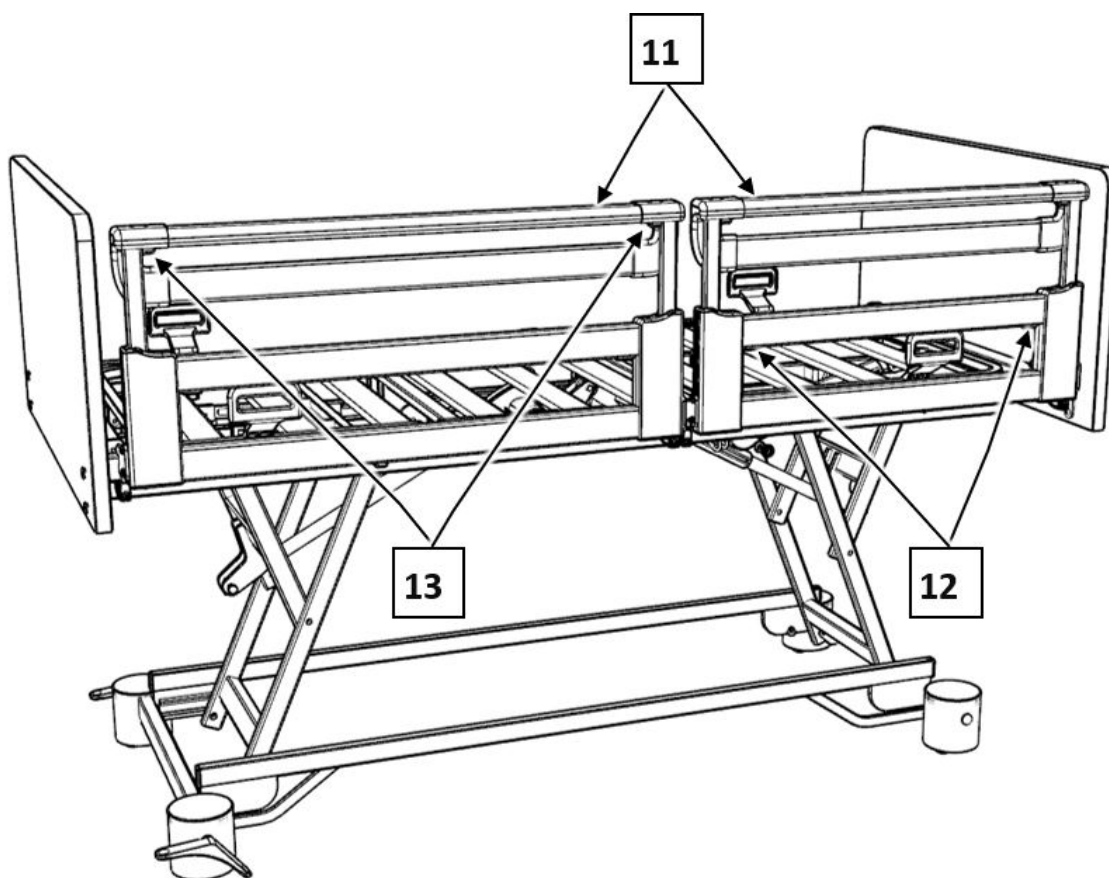

[1] Footboard	[2] Lower leg rest handle (both sides) / mattress retainer bar
[3] Backrest handle (both sides) / mattress retainer bar	[4] Adapter sleeves for patient lifting pole (head end) 2x
[5] Headboard	[6] Side panels (both sides) 4x
[7] Brake lever for operating castor brakes, foot end (both sides)	[8] "Easy Click" full-length safety side (DSG) bars (4x)
[9] Full-length safety side release button (4x)	[10] Side panel (one-piece), only possible in conjunction with full-length safety sides (DSG) (2x).
[11] "Easy Switch" split safety side (TSG) (both sides, telescopic)	[12] Release buttons for lower bar
[13] Release buttons for upper bar	

Contents

Part A: General Information

1	Address, Market Information.....	1
1.1	Address, market information.....	1
2	Foreword.....	2
3	Conventions of this Instruction Manual.....	3
3.1	Safety information.....	3
3.2	Icon information.....	4
4	Product Description.....	5
4.1	Use for the intended purpose.....	5
4.2	Contraindications.....	6
4.3	Components of the Bed.....	7
4.3.1	Mattress base frame.....	7
4.3.2	Safety side (optional).....	7
4.3.3	Electrical adjustment system.....	7
4.3.4	Optional equipment.....	8
4.4	Mattress Base Sizes.....	9
4.5	Technical Data.....	9
4.5.1	Type plate.....	9
4.5.2	PID Number.....	11
4.5.3	Materials used.....	11
4.5.4	Dimensions and weights.....	12
4.5.5	Adjustment ranges.....	12
4.5.6	Ambient conditions.....	12
4.5.7	Classification.....	13
4.5.8	Electrical data.....	14
4.5.9	Electrical connection diagram.....	16
4.5.10	Information on electromagnetic compatibility (EMC).....	20



1 Address, Market Information

1.1 Address, market information

Manufacturer

Burmeier GmbH & Co. KG

(A Stieglmeyer-Group company)

Industriestraße 53 / 32120 Hiddenhausen / Germany

Tel.:+49 (0) 5223 9769 - 0 • Fax:+49 (0) 5223 9769 - 090

Email:info@burmeier.com

Internet:www.burmeier.com

Service Centre

To order replacement parts in Germany and for any servicing requirements or other questions, please contact our service centre:

Burmeier GmbH & Co. KG

(A Stieglmeyer-Group company)

Industriestraße 53 / 32120 Hiddenhausen / Germany

Tel.:+49 (0) 5223 9769 - 0 • Fax:+49 (0) 5223 9769 - 090

Email:info@burmeier.com

Internet:www.burmeier.com

Market Information

Customers outside Germany can contact our distribution companies in their particular country if they have any questions. Contact details can be found on our website.

This product is not licenced for use on the North American market. This applies particularly to the United States of America. The distribution and use of the care bed in these markets, including through third parties, is prohibited by the manufacturer.

2 Foreword

Dear Customer,

Burmeier has built this bed to give you the best possible help with the challenges posed by nursing and caregiving. We passionately pursue the goal of developing products that are durable and of a high-quality. Our products should make residents feel as safe and comfortable as possible during their stay in bed and also lighten the workload of nursing and care staff. For this reason, the electrical safety and all functions are tested prior to delivery. Each bed leaves our factory in perfect condition.

Correct operation and care are necessary to keep the bed in excellent condition during long-term use. Please therefore read and observe these instructions carefully. They will help you to put the bed into service for the first time and to use it on a daily basis. This instruction manual contains all the information you will need to control and handle this bed safely and easily, for you as the operator and your specialist staff and carers. It is a practical reference book and should be kept close to hand at all times.

Even after you have purchased a bed, Burmeier is still on hand to help at any time. We provide customised solutions in all matters relating to inspection and maintenance, repair and process optimisation. You can contact our service centre by phone at +49 (0) 5223 9769 - 0.

We wish you and your staff every success and satisfaction in caring for your residents.

Burmeier GmbH & Co. KG

3 Conventions of this Instruction Manual

3.1 Safety information

At the time of delivery, the care bed Regia represents state-of-the-art technology and has been tested by an independent testing institute.

Only use the care bed Regia if it is in perfect working order.

Explanation of the safety symbols used

In this instruction manual, safety information is displayed in the following way:

WARNING

WARNING

- WARNING indicates a potentially hazardous situation that, if not avoided, could result in death or serious injury.

CAUTION

CAUTION

- CAUTION indicates a potentially hazardous situation that, if not avoided, could result in minor or moderate injury.

ATTENTION

ATTENTION

- ATTENTION indicates a harmful situation that could result in the following consequences: The device or something around it could be damaged.

The safety symbols used are not a substitute for the written safety information. It is important therefore to read the safety information and follow the instructions exactly!

3.2 Icon information

General information and cross-references will be displayed in the following way:

 General information, tips and helpful courses of action.

Cross-reference or active link: Indicates the chapter of the instruction manual and the page number where you can find specific information. Example: [Part A: Safety information](#) » [3](#).

4 Product Description

4.1 Use for the intended purpose

- This bed was developed as a comfortable solution for caring for persons in need of care or infirm persons in homes for the elderly, as well as in nursing homes. Furthermore, it was developed as a supporting solution for home care, for infirm, disabled or frail persons. It is designed to support this care.
- The use of this care bed in hospitals is only permitted in rooms designed for medical treatment of the application group 0 (in accordance with DIN VDE 0100 Part 710).
- Further details on permissible environments for use can be found in chapter [Part A: Ambient conditions](#) » 12. Further information on possible electromagnetic influences can be found in the chapter [Part A: Information on electromagnetic compatibility \(EMC\)](#) » 20
- This bed must only be used as a single bed.
- This bed may be intended for care under the supervision of a doctor and be used for diagnosis, treatment or observation of the resident. It is therefore equipped with a locking function of the electrical adjustment devices.
- This bed has no special connectors for potential equalisation. Please pay attention to this before connecting additional mains-operated (medical) electrical equipment. If necessary, further advice on additional protective measures can be found:

- In the instruction manuals of these additional mains-operated electrical devices (e.g. compressed air positioning systems, infusion pumps, enteral feeding devices, etc.)
- In the DIN EN 60601-1-1 standard (Safety of Medical Electrical Systems)
- In the current issue of the VDE 0107 standard (High-voltage Installations in Hospitals)
- This bed may be operated without restrictions with a permanent maximum load of 225 kg (resident and accessories).
- The permitted weight of the resident depends on the total weight of accessories attached at any time (e.g. respirators, infusions,...)

Weight of accessories (incl. mattress)	Maximum permitted resident weight
10 kg	215 kg

Weight of accessories (incl. mattress)	Maximum permitted resident weight
40 kg	185 kg

- Please refer to the safety information provided in the chapter [Part B: Safety Information](#) » [3](#), especially in the case of residents in poor clinical condition.
- This bed may be operated only by persons who have received instruction in its safe operation.
- This bed is suitable for multiple use. When re-using the bed, pay attention to the necessary requirements:
 - See chapter [Part B: Cleaning and Disinfection](#) » [42](#)
 - See chapter [Part B: Maintenance](#) » [47](#)
- The bed may be moved within the room even when the resident is lying in bed. Adjust the mattress base to a flat home position at its lowest level.
- This bed may only be used under the operating conditions described in this instruction manual. Its use for any other type of application is deemed to be contrary to the intended purpose.
- This bed must not be modified without authorisation by the manufacturer.

4.2 Contraindications

This bed is only suitable for residents who do not fall below the following minimum body size/weight:

- Height: 146 cm
- Weight: 40 kg
- Body mass index "BMI": 17

BMI calculation:

BMI = weight of patient (kg) / height of patient (m)²

Example a:

41 kg / (1.5 m x 1.5 m) = 18.2 = OK!

Example b:

35 kg / (1.5 m x 1.5 m) = 15.6 = Not OK!

CAUTION

Risk of injury

Failure to heed this warning may result in physical injury to the resident due to entrapment or crushing of limbs.

- Owing to the smaller limbs of residents with a body height/weight that is less than this, there is an increased risk of entrapment between the open spaces of the safety sides when safety side systems are used.

4.3 Components of the Bed

The bed is delivered unassembled so that it can be transported to any room. It consists of a chassis, a headboard, a footboard, a mattress base frame and the side panels. The bed is equipped with four castors which are fitted with a locking brake

4.3.1 Mattress base frame

The mattress base frame is divided into a backrest, a fixed middle section, a thigh rest and a lower leg rest. All rests are adjustable. The mattress base height can be adjusted horizontally. A handset controls all electrical adjustments. The entire mattress base and all parts of the bed that can be reached by a resident who is lying in the bed count as application parts.

4.3.2 Safety side (optional)

At the customer's request, the bed can be equipped with safety sides to protect the resident from falling out of bed. The safety sides can be raised from the lowered position beside the mattress base to protect the resident.

4.3.3 Electrical adjustment system

The bed's electrical adjustment system is first-error-secure, flame-resistant (V0) and consists of:

- An "external" switch mode power supply.
The switch mode power supply consists of: Voltage transformer and low voltage connection cable. The voltage transformer generates a protective low voltage that is safe for residents and users. The switch mode power supply provides all drives (motors)

with protective low voltage using a connection cable. The socket available on the chassis is protected against the ingress of water. **Electricity only flows from the external switch mode power supply unit to the bed while the handset is being used.**

- a handset with a strong hook.

The user can lock the adjustment options on the handset if the poor clinical condition of the resident necessitates this.

- The central bus control unit, containing plug-in connections for all drive motors and the handset that work with protective low voltage.
- two drive motors for horizontal height adjustment.
- a drive motor for the thigh rest.
- a drive motor for the backrest.

4.3.4 Optional equipment

Mechanically

- Safety sides (full-length or split) on both sides of the bed
- One-piece side panels (2x) only possible in conjunction with full-length safety sides.
- Removable comfort mattress base comprises 50 individual spring elements. These elements are designed to mould themselves closely to the shape of the body and help to ventilate the mattress. Their flexibility also ensures that the pressure is optimally distributed. The comfort mattress base also significantly contributes to preventing pressure ulcers.
- Bed extension, adaptable, extends the bed by approximately 20 cm. If full-length or combined safety sides are used, longer safety side bars must be fitted. Please consult our sales department if required (see [Part B: Replacement parts](#) » 55).
- Pillow holder, for attaching at the foot end; can be pulled out from under the mattress base
- Wall deflection roller, effective in horizontal and vertical directions

Electric

- Trendelenburg handset: Optional equipment for use when the bed is used for long-term medical care.
- Rechargeable battery: In emergency use, they are used to operate the electrical drive system independently of the mains electricity supply.
- Under bed light: Provides safe orientation during the night and can reduce the risk of falls.
- LED reading light: With a built-in power supply

4.4 Mattress Base Sizes

The bed can be ordered in the following sizes.



 This instruction manual may describe functions or features that your model of bed does not have.

Mattress base size	External dimensions
90 x 200 cm (standard)	101 x 211 cm
100 x 200 cm (optional)	111 x 211 cm
90 x 220 cm (optional)	101 x 231 cm
100 x 220 cm (optional)	111 x 231 cm

4.5 Technical Data



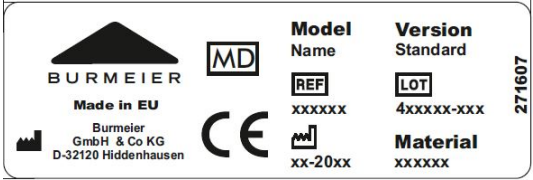







4.5.1 Type plate



You can find the type plate on the bed frame at the head end. The type plate contains the following information:

	
Type plate, example	Type plate (electrical data), example

Explanation of the graphical symbols used:

Model	Bed model
Material	Material variant
Version	Variant (if applicable)
	Item number

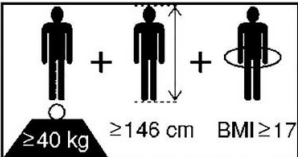
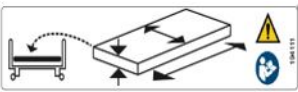
Explanation of the graphical symbols used:	
	Order number
	Date of manufacture (week/year)
	The article is a medical device
	Device with type BF applied part in accordance with IEC 601-1 (special protection against electric shock)
	Protection Class II device, shock-proof
	Only for use in enclosed spaces – do not use outdoors
	Dispose of electrical components in accordance with the WEEE Directive. Do not dispose of as household waste!
	Attention! Follow the operating instructions
Total  :	Total bed weight, 130 kg maximum
IP X4	Protection of electrical equipment from water splashing from any direction
	Conformity mark according to Medical Devices REGULATION (EU) 2017/745 (MDR)
	Safe working load

Explanation of the graphical symbols used:	
	Permissible weight of patient
	Minimum resident measurements/weight: Height: 146 cm, weight: 40 kg; body mass index "BMI": 17
	Only use mattresses that are approved by the manufacturer.
	Lock the handset if the resident could be at risk due to inadvertent motorised adjustments.

4.5.2 PID Number

Relevant order information is summarised for the manufacturer under the PID number. Have the PID number ready any time you contact your specialist dealer. You can find the PID no. on the bed frame at the head end.



Part A: Image1:
PID number, example

4.5.3 Materials used

For the most part, the bed was manufactured from steel profiles whose surfaces were finished with a polyester powder coating or a metal coating of zinc or chromium. The head and footboards, safety side bars and sprung slats are made of wood or wood products whose surfaces have been finished.

All surfaces that can be touched during normal use have been tested for bio-compatibility and are harmless to humans when in contact with the skin.

4.5.4 Dimensions and weights

Assembled bed with safety sides:	
Mattress base dimensions	Depending on the version of the headboard and footboard, see chapter Part A: Mattress Base Sizes » 9
Note: Please refer to the dimensioned sketch on our website for further details: www.burmeier.com/de/information/downloads .	
Total weight, depending on model	from approx. 118 kg to approx. 130 kg
Safe working load	225 kg
Disassembled bed:	
Headboard and footboard	14 kg
Chassis with motor	65.5 kg
Mattress base frame without motors	approx. 38 kg
Telescopic safety side (TSG)	6 kg/each
Patient lifting pole	5 kg
Side panel	4.2 kg

4.5.5 Adjustment ranges

- Electrical height adjustment range for mattress base: approx. 25 - 80 cm.
- Electrical backrest adjustment from 0° to approx. 66°.
- Electrical thigh rest adjustment from 0° to approx. 40°.
- Moves on four centrally-locking castors.

4.5.6 Ambient conditions

Noise level during adjustments	max. 48 dB(A)
The ambient conditions stated below must be maintained:	
For storage/transport:	

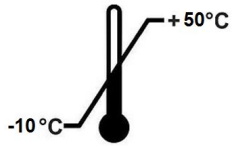
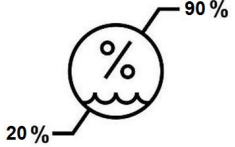
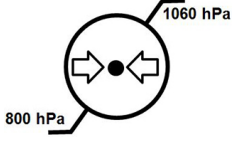
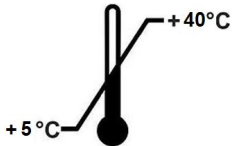
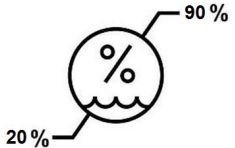
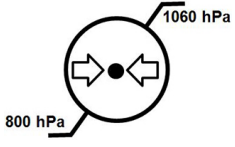
Storage temperature	min. -10°C, max.+50°C	
Relative humidity (not condensed)	Min. 20 %, max. 80 %	
Air pressure (at altitude ≤ 3000 m)	Min. 700 hPa, max. 1060 hPa	
In operation:		
Ambient temperature	min. + 5°C max. + 40°C	
Relative humidity (not condensed)	Min. 20 %, max. 80 %	
Air pressure (at altitude ≤ 3000 m)	Min. 700 hPa, max. 1060 hPa	

4.5.7 Classification

- This bed fulfils all the requirements of the Medical Device Regulation (EU) 2017/745 (MDR).
- This bed is classified as a Class I active medical product with type BF application parts.
- EMDN- Code:V08060101: HOSPITAL/HOME CARE ELECTRIC MEDICAL BEDS
- For use in the following application environments in accordance with IEC 60601-2-52:

3:	Long-term care in a medical facility in which medical supervision is required and monitoring is provided if required. A medical electrical device used in medical
----	---

	procedures can be provided to help maintain or improve the condition of the resident. (e.g. retirement and nursing homes, rehabilitation facilities and geriatric institutions)
4:	Care in the home. A medical electrical device is used to alleviate or compensate for injuries, disabilities or illnesses.

4.5.8 Electrical data

Control unit for external switch mode power supply	
Type	LINAK CB06 OpenBus®
Input voltage	20-34V DC
Max. current input	DC 8 A
Internal device fuse	2-fold electronic, automatic-resetting overload protection;
Duty cycle	Intermittent duty, 2 min ON / 18 min OFF
Protection category	IP X4
Classification	Protection Class II, Type B, MDR classification Class I, not for use in explosive atmospheres

External switch mode power supply	
Type	Linak SMPS 20
Input voltage	AC 230 V, ± 10 %, 50/60 Hz
Max. current input	AC 2.5 A
Output voltage	Max. DC 34 V
Output current, electronically limited,	max. 10 A, activated via remote signal
Duty cycle	Intermittent duty, 2 min ON / 18 min OFF
Protection category	IP X4

External switch mode power supply

Classification	Protection Class II, Type B, MDR classification Class I, not for use in explosive atmospheres
----------------	---

External rechargeable battery (optional)

Type	Linak BA 18013
Voltage/capacity	DC 24 V/ 1.2 Ah (lead-gel technology)
Max. charging current/ charging time	0.3 A/ 8-10 h Charging only admissible with Linak control units
Internal device fuse	10A safety fuse
Protection category	IP X6
Charger for external battery: Possible with all aforementioned LINAK control units.	

Handset with locking function

Type	Linak HL 7xx -OpenBus®
Protection category	IP X4

Additional handset for Trendelenburg/reverse-Trendelenburg position (optional)

Type	Linak HL 7xx -OpenBus®
Protection category	IP X4

Motors for mattress base height

Type	Linak LA 27
Force/installation dimension/lift	6000 N / 470 mm / 250 mm
Path feedback	Digital Hall
Input voltage	Max. DC 34 V

Motors for mattress base height	
Duty cycle	Intermittent duty: 2 min ON / 18 min OFF
Protection category	IP X4

Backrest motor	
Type	Linak LA 27
Force/installation dimension/lift	4000 N / 438 mm / 200 mm
Input voltage	Max. DC 34 V
Duty cycle	Intermittent duty: 2 min ON / 18 min OFF
Protection category	IP X4

Thigh rest motor	
Type	Linak LA 27
Force/installation dimension/lift	4000 N / 272 mm / 70 mm
Input voltage	Max. DC 34 V
Duty cycle	Intermittent duty: 2 min ON / 18 min OFF
Protection category	IP X4

4.5.9 Electrical connection diagram

All plugs are connected to the control unit. To prevent the plugs from being inadvertently disconnected, they are secured with a plug cover. Before replacing a plug, lift this cover carefully using a screwdriver.

 External switch mode power supply:

With this control unit, the safety extra-low voltage supply cable that leads to the external switch mode power supply is permanently connected and cannot be disconnected. This prevents a 230V mains cable from being inadvertently connected.

This bed can be delivered with standard equipment and also with optional equipment. In the following chapters you will find the connection diagrams of both equipment variants.

The following figure will help you to localise the electrical components on the bed.

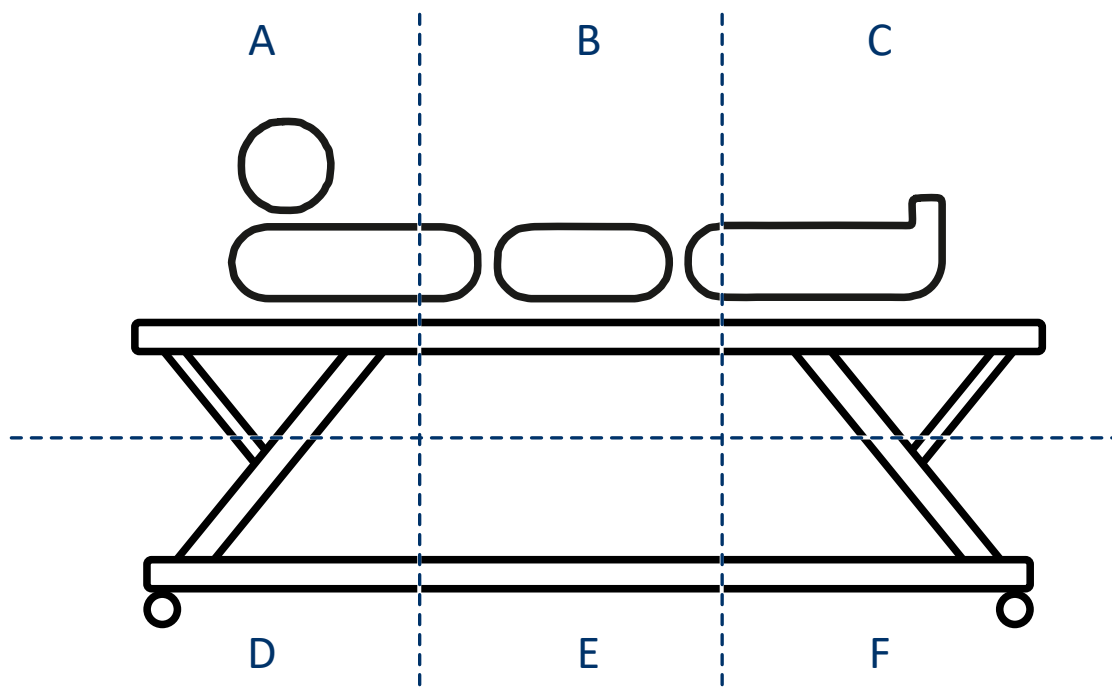

Part A: Image2:
Location of the electrical components

A: Head end, high up

B: Centre of bed, high up

C: Foot end, high up

D: Head end, low down

E: Centre of bed, low down

F: Foot end, low down

4.5.9.1 Standard features

i The letters in the following tables refer to the previous picture “Location of the electrical components”. This indicates where the component is located in the bed.

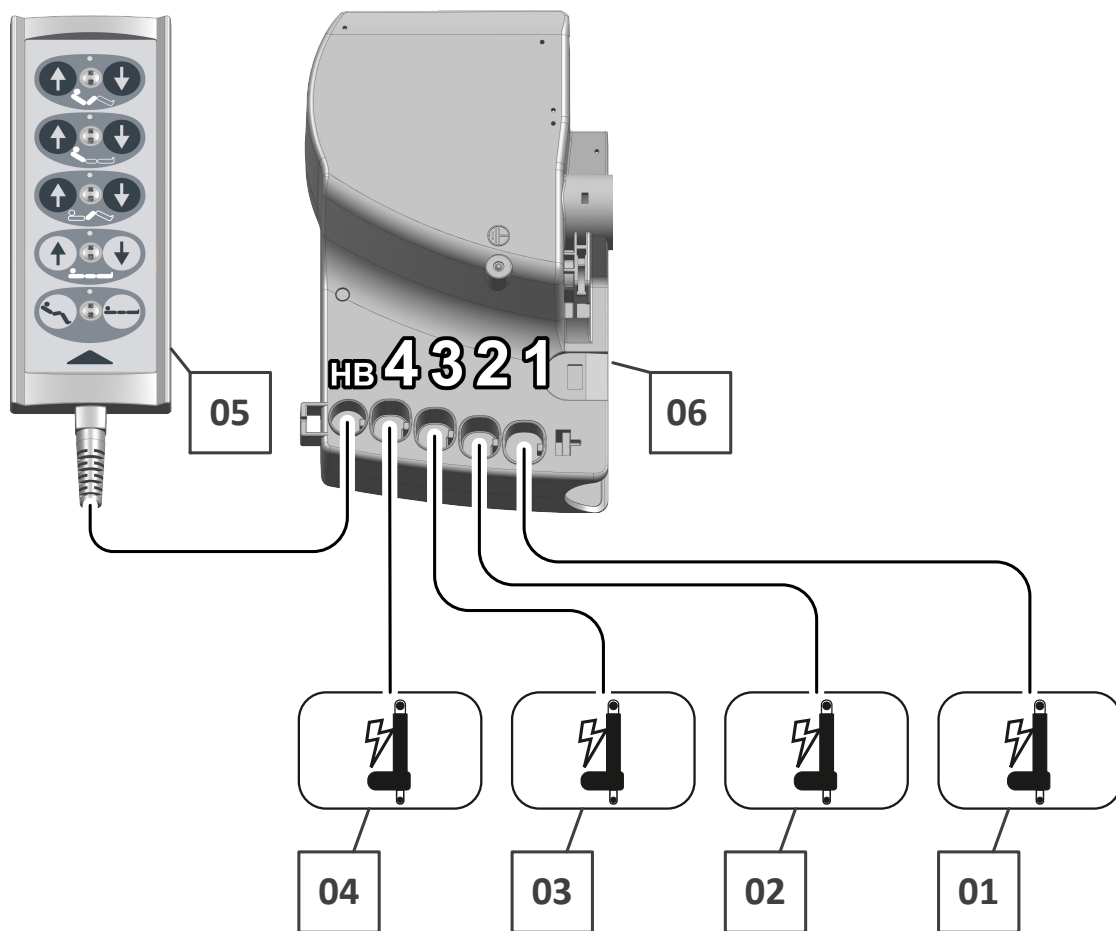

1: Backrest motor → B

2: Height adjustment motor at head end → E

3: Thigh rest motor → B

4: Height adjustment motor at foot end → E

5: Conventional handset → B

6: Control unit → A

4.5.9.2 Optional equipment



Components with an asterisk must be inserted into the correct connection socket only.

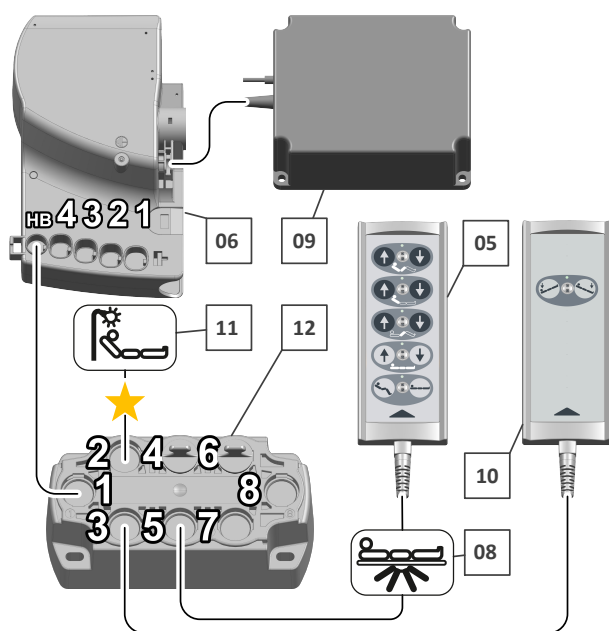
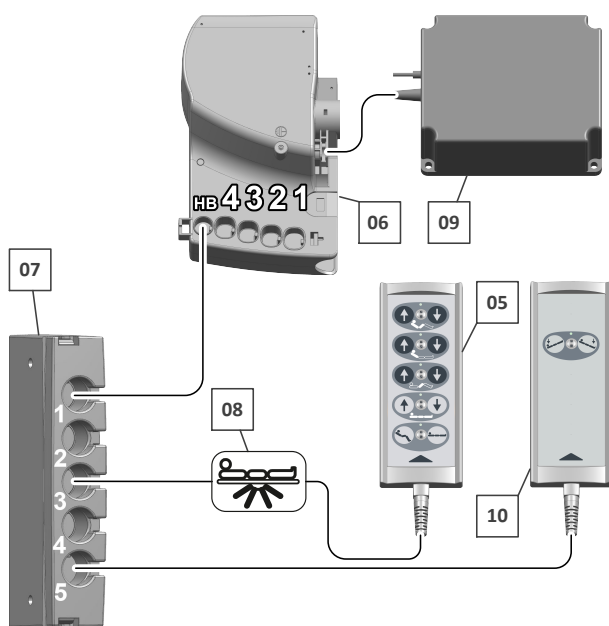

7: Distributor box (MJB5) → A

8: Under bed light → B

9: Rechargeable battery → A

10: Trendelenburg handset → B

11: Reading lamp → A

12: Distributor box (MJB8) → A

4.5.10 Information on electromagnetic compatibility (EMC)

i To ensure electromagnetically interference-free operation, only use cables and accessories that are approved by the manufacturer (see also the chapter “Replacement Parts; Accessories” in the instruction manual for the bed).

For the intended use as described in the main instruction manual, no significant performance limitations of this bed are known/expected as a result of possible electromagnetic interference from neighbouring devices.

ATTENTION

Material damage

Failure to heed this warning may result in malfunctions and material damage.

- The use of accessories, transducers and cables other than those supplied by BURMEIER for this bed may result in increased electromagnetic emissions or reduced electromagnetic immunity of the bed and may lead to incorrect operation.
- The use of this device next to other devices should be avoided, as this could result in incorrect operation. If such use is nevertheless necessary, this device and the other devices should be monitored to ensure that they are working properly.
- Portable RF communication devices (radio, mobile phones etc.), including their accessories (such as antenna cables and external antennas) should not be used at a distance of less than 30 cm from the electrical parts and cables of this bed. Failure to observe this may result in a reduction in the performance of the device.

The bed is intended for use in the electromagnetic environment described below. The operator or user of the bed must ensure that it is used in such an environment.

This device is compliant with the following EMC standards regarding interference emissions and immunity:

Ambient limit values of the interference emissions	
Phenomenon	Home healthcare environment
Conducted and radiated interference emissions	CISPR 11
Harmonic distortions	See IEC 61000-3-2
Voltage fluctuations and flicker	See IEC 61000-3-3

Sheathing		
Phenomenon	EMC basic standard or test method	Immunity level (test + compliance)
		Home healthcare environment
Electrostatic discharge (ESD)	IEC 61000-4-2	+/- 8 kV contact +/- 2 kV, +/- 4 kV, +/- 8 kV, +/- 15 kV; +/- 25 kV air
High-frequency electromagnetic fields	IEC 61000-4-3	10 V/m ; (80 MHz to 2.7 GHz; 80% AM at 1 kHz)
High-frequency electromagnetic fields in the immediate vicinity of wireless communication devices	IEC 61000-4-3	See separate table zz (at the end of this chapter)
Magnetic fields with rated power frequencies	IEC 61000-4-8	See separate table zz (at the end of this chapter)

AC port for supply input		
Phenomenon	EMC basic standard	Immunity level (test + compliance)
		Home healthcare environment
Electrical fast transient disturbances/bursts	IEC 61000-4-4	+/- 2 kV; 100 kHz repetition frequency
Electrical surges: conductor to conductor	IEC 61000-4-5	+/- 0,5 kV; +/- 1kV
Conducted interference induced by high-frequency fields	IEC 61000-4-6	3 V; 0.15 MHz to 80 MHz; 6V in ISM and amateur radio frequency bands between 0.15 MHz and 80MHz 80% AM at 1 kHz
Voltage dips	IEC 61000-4-11	0% UT; 1/2 period; at 0, 45, 90, 135, 180, 225, 270 and 315 degrees
		0% UT; 1 period; and 70% UT; 25 periods; single-phase at 0 degrees Celsius
Voltage interruptions	IEC 61000-4-11	0% UT; 250 periods

Ports for signal input/signal output parts		
Phenomenon	EMC basic standard	Immunity level (test + compliance)
		Home healthcare environment
Electrostatic discharge (ESD)	IEC 61000-4-2	+/- 8 kV; contact +/- 2 kV, +/- 4 kV, +/- 8 kV, +/- 15 kV; +/- 25kV air;
Electrical fast transient disturbances/bursts	IEC 61000-4-4	+/- 1 kV; 100 kHz repetition frequency
Conducted interference induced by high-frequency fields	IEC 61000-4-6	3 V; 0.15 MHz to 80 MHz; 6V in ISM and amateur radio frequency bands between 0.15 MHz and 80MHz 80% AM at 1 kHz

Table zz: Test specifications for the immunity of sheathings to high-frequency wireless communication equipment						
Test frequency MHz	Frequency band	Radio service	Modulation	Max. power W	Distance m	Immunity test level v/m
385	380 to 390	TETRA 400	Pulse modulation 18 Hz	1.8	0.3	27
450	430 to 470	GMRS 460 FRS460	FM +/- 5% deviation, 1kHz sine wave	2	0.3	28
710	704 to 787	LTE band 13, 17	Pulse modulation 217 Hz	0.2	0.3	28
745						
780						
810	800 to 960	GSM 800/900 TETRA 800 iDEN820, CDMA 850, LTE band 5	Pulse modulation 18 Hz	0.2	0.3	28
870						
930						
1720	1700 to 1990	GSM 1800 CDMA 1900,	Pulse modulation 18 Hz	2	0.3	28

Table zz: Test specifications for the immunity of sheathings to high-frequency wireless communication equipment

Test frequency MHz	Frequency band	Radio service	Modulation	Max. power W	Distance m	Immunity test level v/m
1845		GSM 1900, DECT, LTE band 1; 3; 4; 25; UMTS				
1970						
2450	2400 to 2570	Bluetooth, WLAN 802.11 b/g/n, RFID 2450, LTE band 7	Pulse modulation 217 Hz	2	0.3	28
5240	5100 to 5800	WLAN 802.11 a/n	Pulse modulation 217 Hz	2	0.3	9
5500						
5785						

Part B: Operator and Technical Personnel

Regia (Standard) care bed

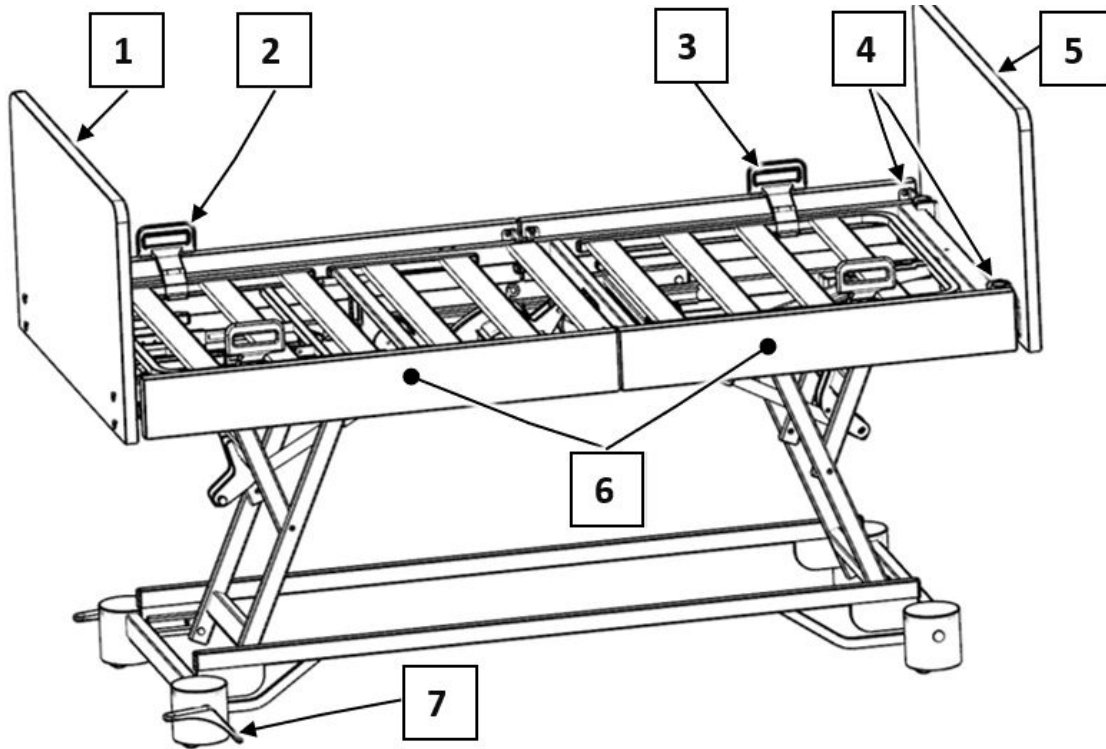

Regia care bed DSG (optional)

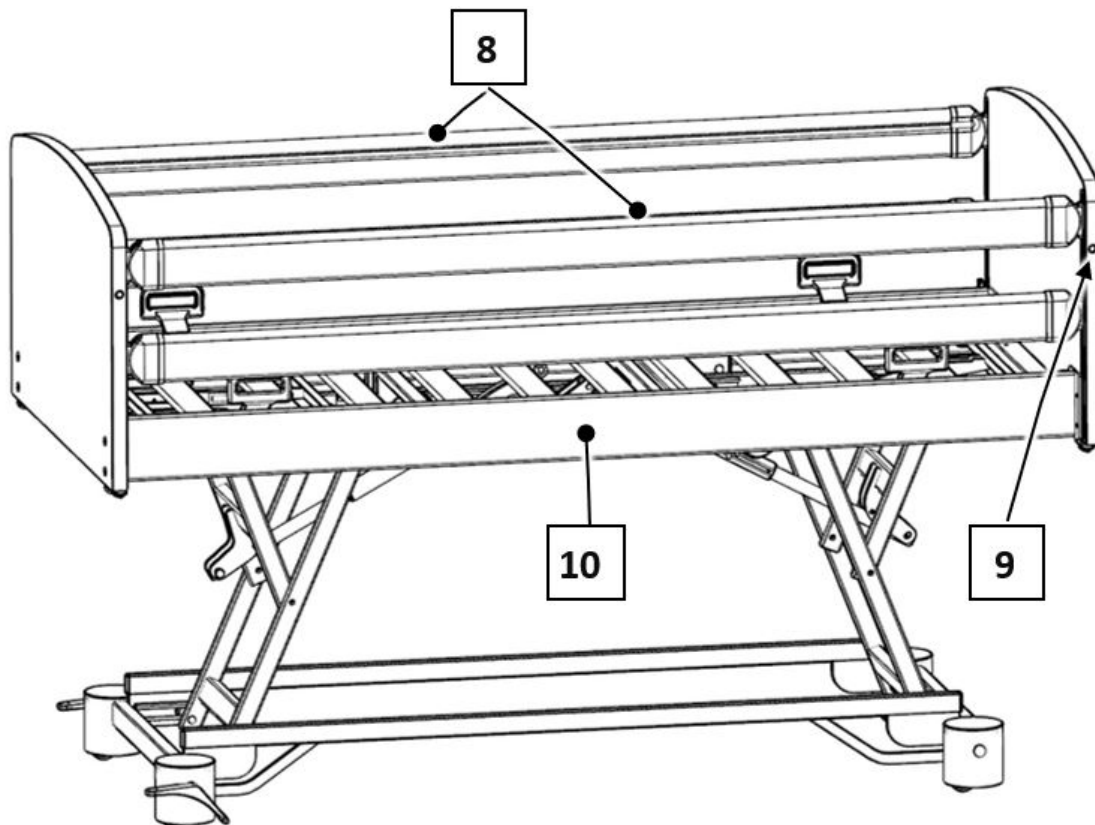

Regia care bed with telescopic safety sides (TSG) (optional equipment)

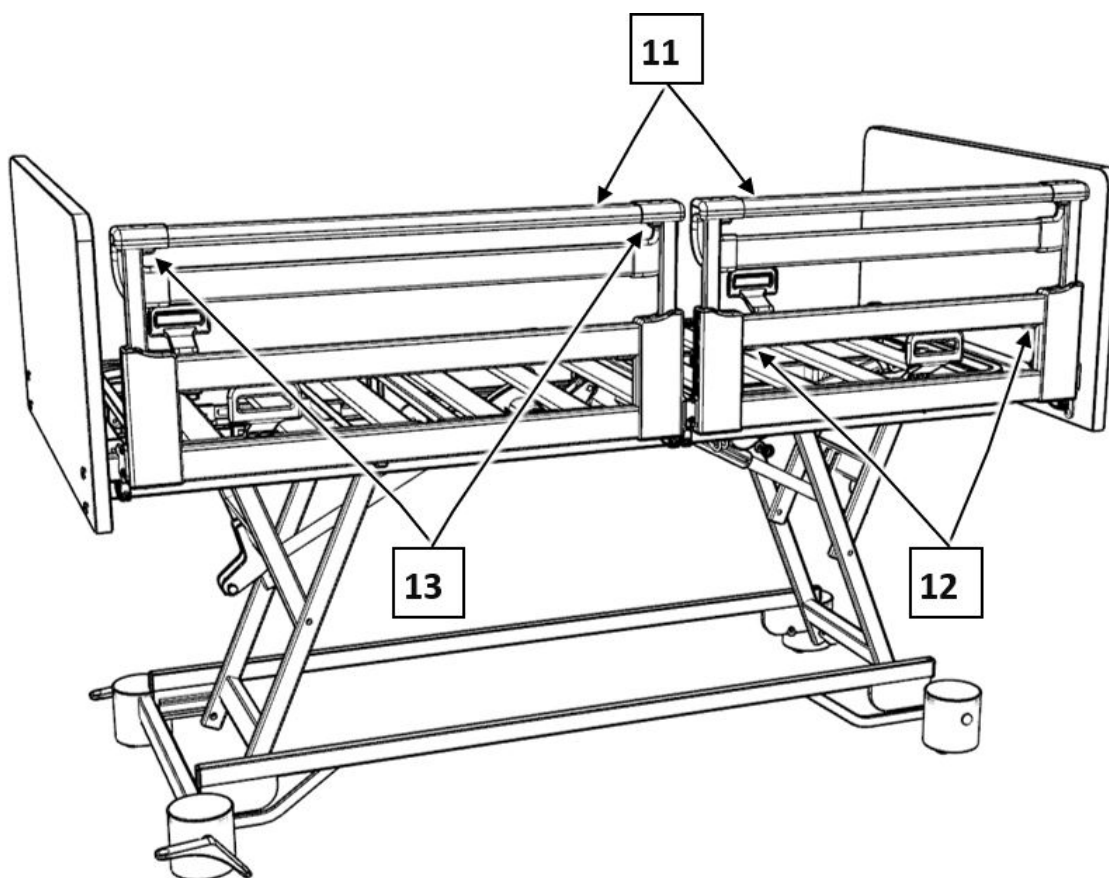

[1] Footboard	[2] Lower leg rest handle (both sides) / mattress retainer bar
[3] Backrest handle (both sides) / mattress retainer bar	[4] Adapter sleeves for patient lifting pole (head end) 2x
[5] Headboard	[6] Side panels (both sides) 4x
[7] Brake lever for operating castor brakes, foot end (both sides)	[8] "Easy Click" full-length safety side (DSG) bars (4x)
[9] Full-length safety side release button (4x)	[10] Side panel (one-piece), only possible in conjunction with full-length safety sides (DSG) (2x).
[11] "Easy Switch" split safety side (TSG) (both sides, telescopic)	[12] Release buttons for lower bar
[13] Release buttons for upper bar	

Contents

Part B: Operator and Technical Personnel

1	Target Groups, Qualifications and Duties.....	1
1.1	Operator.....	1
1.1.1	Responsibilities of the operator.....	1
1.2	Technical Personnel.....	2
2	Safety Information.....	3
2.1	General information.....	3
2.2	Safety Information for Operating the Bed.....	3
2.2.1	Electrical cables and connections.....	4
2.2.2	Operating time of electric drives.....	5
2.2.3	Handset.....	5
2.2.4	Bed adjustment.....	6
2.3	Special Hazards.....	7
2.3.1	Risk of fire.....	7
2.4	Safety Information for Attachments and Additional Equipment.....	8
2.4.1	Use of Resident Lifts.....	8
2.5	Safety information for accessories.....	8
2.6	Safety information for disposal.....	9
3	Assembling the Care Bed.....	10
3.1	Included in the package.....	10
3.2	Location requirements.....	11
3.3	Chassis and Mattress Base Frame.....	11
3.4	Headboard and footboard.....	15
3.4.1	Attachment.....	16
3.4.2	Removal.....	17
3.5	Side panels.....	18
3.5.1	Split side panels.....	18
3.5.2	Full-length side panels.....	22
3.6	Safety sides.....	23

3.6.1	No safety sides (standard).....	24
3.6.2	Full-length safety sides (DSG).....	24
3.6.3	Split safety sides.....	27
3.7	Adaptable bed extension (option).....	36
3.7.1	Installation (with split safety sides).....	36
3.7.2	Removal.....	37
3.8	Comfort mattress base (optional).....	38
3.9	Electrical connection.....	39
4	Putting into Service.....	41
4.1	Putting into service.....	41
4.2	Making Ready for Operation.....	41
5	Cleaning and Disinfection.....	42
5.1	Safety information on cleaning and disinfection.....	42
5.2	Cleaning and Disinfection Plan.....	43
5.3	Instruction of Care Staff and Technical Personnel.....	43
5.4	Cleaning agents and disinfectants.....	44
5.5	Handling Cleaning and Disinfection Agents.....	46
6	Maintenance.....	47
6.1	Legal principles.....	47
6.2	Inspections and Function Checks.....	48
6.2.1	Operating Current Test Procedure.....	49
6.2.2	Inspection report.....	50
6.3	Replacement parts.....	55
7	Replacement of electrical components.....	56
7.1	Safety information.....	56
7.2	Replace the handset with a new one.....	57
7.3	Replace the motor.....	59
7.4	Connecting a reading lamp (optional).....	59
7.5	Replace the control unit.....	59
7.6	Initialising the control unit.....	60
7.7	Control unit – Reset.....	62

8	Troubleshooting.....	63
8.1	Faults and their rectification.....	63
9	Decommissioning.....	64
10	Dismantling the Care Bed.....	65
11	Disposal.....	66
11.1	Disposal of the Bed.....	66
11.2	Disposal of Packaging.....	66
11.3	Disposal of Electrical Components.....	66
12	Appendix.....	67
12.1	Accessories.....	67
12.1.1	Mattress requirements.....	67
12.1.2	Safety Side Requirements.....	68
12.2	Translation of EC Declaration of Conformity.....	68



1 Target Groups, Qualifications and Duties

1.1 Operator

Operators (e.g. medical equipment retailers, specialist dealers, health insurance) are all natural or legal persons who use this bed or on whose behalf it is used. It is a requirement that the operator duly instructs care staff in its use.

1.1.1 Responsibilities of the operator

Please observe your obligations as the operator in accordance with the Medical Devices Operator Ordinance (Medizinprodukte-Betreiberverordnung, German abbreviation: MPBetreibV), to ensure that this medical product is always operated safely and with no risk to residents, care staff or third parties. In other countries the relevant national regulations concerning the duties of the operator must be followed!

Only permit persons who have been properly instructed to use this bed!

- In Germany: Ensure that care staff know where this instruction manual is kept, in accordance with the Medical Devices Operator Ordinance (MPBetreibV) § 9! In other countries, the relevant national regulations must be complied with!
- Using this instruction manual, which is provided with this care bed, ensure that care staff is instructed in the safe operation of this bed before using it for the first time!
- Draw every user's attention to the possible hazards that can arise if the bed is improperly used. This applies in particular to the use of electrical drives and safety sides!
- Make sure that substitute staff are also sufficiently well instructed in the safe operation of the care bed!
- Use this bed only as intended by the manufacturer, in accordance with the instructions in this manual.

Check to ensure that the safety instructions are adhered to!

If the bed is in long-term use, test the functions and check for visual damage in accordance with chapter [Part C: Maintenance](#) » [35](#) after a reasonable period of time!

If the care bed changes ownership, the instruction manual must be handed over with the bed.

If any other equipment is attached to the bed, (e.g. compressors for positioning systems, etc.), ensure that this is securely fastened and is functioning properly.

If anything is unclear, please contact the manufacturer of the device, or Burmeier.

1.2 Technical Personnel

Technical personnel comprises persons who, based on their training or briefing, are qualified to deliver the care bed, assemble or dismantle it and to transport the bed. Furthermore, this personnel is briefed in the cleaning and disinfection instructions.

2 Safety Information

2.1 General information

Before using the care bed for the first time:

- Read this instruction manual in full. This will help you to prevent injuring persons or damaging materials as a result of incorrect handling.
- Please read and note the information on approved mattresses in accordance with the standard DIN 13014, (see [Part B: Mattress requirements](#) » 67).
- Clean and disinfect the care bed before using it for the first time.

Before using a care bed, the user's personnel must check that the care bed is fully functional and in perfect working order, and must observe the instructions in the manual in accordance with the Medical Devices Operator Ordinance (MPBetreibV) § 2. This also applies for accessories.

This care bed fulfils all the requirements of the Medical Device Regulation (EU) 2017/745 (MDR) and is considered a Class I medical device in accordance with the classification rules.

The safety of this care bed has been tested by an independent testing institute. Any item of technical electrical equipment can prove hazardous if not used properly.

Please observe your obligations as the operator in accordance with the Medical Devices Operator Ordinance (Medizinprodukte-Betreiberverordnung, German abbreviation: MPBetreibV), to ensure that this medical product is always operated safely and with no risk to residents, care staff or third parties.

This instruction manual contains safety information which must be followed. All persons who work on or with the care bed must be familiar with the contents of this instruction manual and must follow the safety information.

2.2 Safety Information for Operating the Bed

This care bed is not suitable for residents under 146 cm in height or for small children.

This care bed may only be operated by persons who have received instruction from the operator in its safe operation.

Electrical adjustments are only possible when the care bed is properly connected to the mains supply.

2.2.1 Electrical cables and connections



WARNING

Risk of injury

Failure to heed this warning may result in fatal injuries due to damaged mains power cables.

- Do not use damaged mains power cables! This can lead to electric shock, fire and other hazards as well as malfunctions.
- Replace damaged mains power cables immediately!
- Route the mains cable in such a way that it cannot be pulled, driven over or damaged by moving parts, or in any other way, when the bed is operated. Before moving the bed, always make sure that you have unplugged it from the mains supply.
- Before moving the bed, always make sure that you have unplugged it from the mains socket.
- Hang the mains cable in the mains cable holder provided on the headboard to ensure that it will not fall off or trail on the floor.
- At weekly intervals when the bed is being used, carry out a visual inspection of the mains cable to check for damage (scuffing, exposed wires, kinks, pressure points, etc.). A check should also be performed whenever the cable has been subjected to any mechanical load, e.g. has been driven over by the bed itself or by an equipment trolley, or whenever the cable has been bent, stretched or violently pulled, e.g. due to the bed rolling away while it is still plugged into the mains socket, and before plugging the cable back into the mains socket whenever the bed has been moved or relocated.
- Check the strain relief of the power mains cable regularly to ensure that it is securely fixed.
- Do not place multiple socket outlets under the bed. This could cause electrical hazards due to damaged mains cables or penetrating fluids.
- Do not continue to use the bed if you suspect that the mains cable could be damaged.

2.2.2 Operating time of electric drives

-  Continuous operation must not exceed two minutes! After this time, a rest period of at least 18 minutes must be observed. If the electric drive is operated for a much longer period, e.g. due to the resident continually "playing" with the handset, the thermal protection device integrated in the control unit will deactivate power supply for safety reasons. Depending on the extent of overloading, it may take a few minutes until you can carry out any further adjustments. Also read and note the additional information contained in the chapter [Part C: Troubleshooting](#) » 31.

2.2.3 Handset

When not in use, stow the handset in such a way that it cannot inadvertently fall off (hang it up by the hook). Make sure that the cable cannot be damaged by moving parts of the care bed.

CAUTION

Risk of injury

Failure to heed this warning may result in physical injury due to unintentional incorrect operation.

Lock the operating functions for the resident on the handset if:

- The resident is unable to operate the bed safely or to free himself/herself from potentially dangerous situations,
- the resident is exposed to an increased risk of entrapment during backrest and thigh rest adjustments when the safety sides are raised,
- The resident could be at risk due to unintentional motorised adjustments,
- Children are left unsupervised in the room with the care bed.

CAUTION

Risk of injury

Failure to heed this warning may result in physical injury due to entrapment or crushing of limbs.

- This bed is only intended for use as a single bed. Keep a minimum safety distance of one bedside cabinet width (approximately 60 cm) between one bed and the next.

- When making any adjustments, always ensure that no limbs belonging to the resident, care staff or other persons, especially playing children, could be trapped underneath the rests or the mattress base during the adjustment.
 - Do not leave children unsupervised in the room with the bed.
 - Adjustments may then be made only by, or in the presence of, a person who has received appropriate instruction.
-

2.2.4 Bed adjustment

ATTENTION

Material damage

Failure to heed this warning may result in the care bed being damaged, which could have an adverse effect on the loading capacity of the care bed or the adjusting functions. Ensure that:

- No obstacles such as bedside cabinets, supply rails, other equipment, chairs or wall protection rails are in the way,
 - There are no objects lying on the chassis,
 - People should not sit on slightly raised sections of the backrest, thigh rests and leg rests.
-

 If the load is too high, an electronic overload switch is activated and the control unit is automatically switched off. When the excess load is removed, the drive unit system can be reactivated by pressing the appropriate button on the handset.

2.3 Special Hazards

2.3.1 Risk of fire

WARNING

Risk of injury

Failure to heed this warning may result in a fire caused by various external factors. To prevent a fire, take the following precautionary measures.

- Use only flame-retardant mattresses and bedding if possible.
- Inform residents that smoking is not allowed in bed.
- Use only suitable mattresses that comply with the German standard DIN 13014 and are not too soft. Furthermore, these mattresses must resist ignition in accordance with DIN EN 597-1 and -2.
- Only use additional devices (e.g. electric blankets) and other electrical devices (e.g. lamps, radios) that are in perfect working order and ensure that their connection cables cannot be damaged by moving parts of the bed.
- Ensure that this equipment is used only for the purpose intended.
- Ensure that this equipment is not inadvertently placed on or under the bedding (danger of overheating)! Use only LED bulbs, as far as possible, since these generate far less heat than conventional or halogen light bulbs.
- Avoid using extension cables or multiple socket bars under the bed (risk of fire due to penetrating fluids).

2.4 Safety Information for Attachments and Additional Equipment

2.4.1 Use of Resident Lifts

ATTENTION

Material damage

Failure to heed this warning may result in material damage due to the use of resident lifts.

- Do not wheel the resident lift under the care bed when this is at its lowest level.
 - Raise the mattress base until it is about 10 cm higher before wheeling the resident lift under the care bed.
-

2.5 Safety information for accessories

ATTENTION

Material damage

Failure to heed this warning may result in incorrect use or use of unsuitable accessories.

- When using external electrical components such as resident lifts, reading lamps, or compressors for positioning systems, ensure that their power cables will not become entangled or damaged by moving parts of the bed.
 - Efficient and safe operation combined with maximum protection of residents can only be guaranteed if original Burmeier accessories designed for the relevant model of bed are used.
-

2.6 Safety information for disposal

WARNING

Risk of infection

Failure to heed this warning may result in infections.
Beds, bed components or accessories that have not been disinfected can become health hazards for people.

- The operator must ensure that all components of the bed that are to be disposed of are not infectious or contaminated.

3 Assembling the Care Bed



- This chapter is intended to be read by professionals employed by the operator or medical supply retailers.
- Helpful assembly videos for setting up the bed can be found on www.burmeier.com/de/information/downloads or directly on YouTube. Please scan the following QR code with your mobile device:



3.1 Included in the package

The bed is delivered unassembled. Two people are required to assemble the bed. The bed is supplied in the following packaging units:

Package	Contents
Box 1	Chassis with height adjustment motor; handset; switch mode power supply
Box 2	Mattress base
Box 3	Headboard and footboard
Box 4 and 5	Side panels and/or safety side (split or full-length)

Remove all packaging materials and cable ties before starting to assemble the bed. Observe the disposal information in the chapter [Part B: Disposal](#) » [66](#).

3.2 Location requirements

Note the following safety relevant aspects to take into account when selecting the site of use:

- There must be sufficient room available to accommodate the bed's entire range of adjustments. Furniture, window sills, etc. must not impede adjustments.
 - The space underneath the bed must remain free.
 - Before using the bed on parquet flooring, check whether the castors will leave stains on the parquet varnish. The bed can be used on tiles, carpet, linoleum or laminate flooring without causing any damage. Burmeier is not liable for any floor damage that may be caused by day-to-day operation.
 - A properly installed 230 volt mains socket must be available as close as possible to the bed.
 - If any other additional equipment is attached to the bed, (e.g. compressors for positioning systems etc.), ensure that this is securely fastened and functions properly. Pay particular attention here to the safe routing of all loose connector cables, tubing, etc.
- If you have any questions or concerns, consult the manufacturer of the additional equipment or Burmeier. To find the address, refer to [Part B: Replacement parts](#) » 55.

3.3 Chassis and Mattress Base Frame

Please note: Individual features in the following illustrations may differ from the features of your bed.

The bed must be assembled by two people.

Tools required: Allen key, 8 mm

1. Remove the chassis from the cardboard box, set it down and remove all packaging foil from the cables.

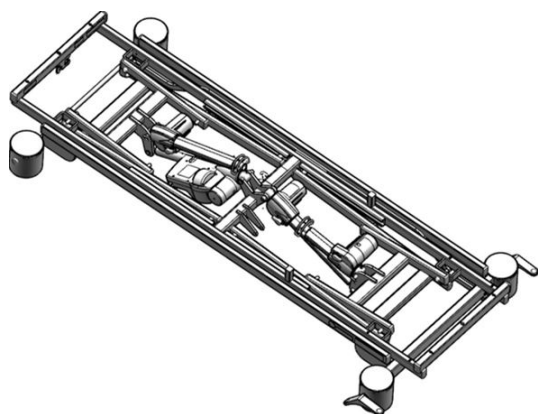

2. The motors of the thigh rest and the back rest have been secured in transport position by the manufacturer. They must first be removed from their transport position.

- Remove the locking pin on the housing.
- Cut through the cable tie on the drive tube.

Note: Pay attention to the cable routing. Place the motors with their locking pins on the floor.

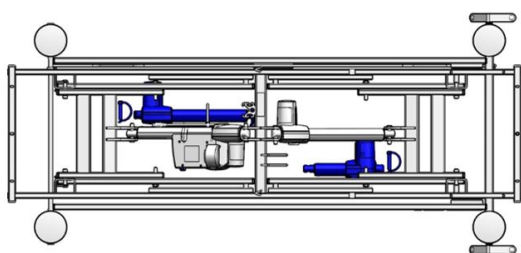

3. Connect the switch mode power supply, see [Part A: Electrical connection diagram](#) » 16.

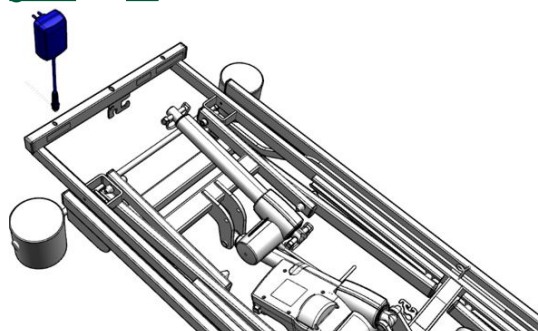

4. Move the chassis to the highest position.

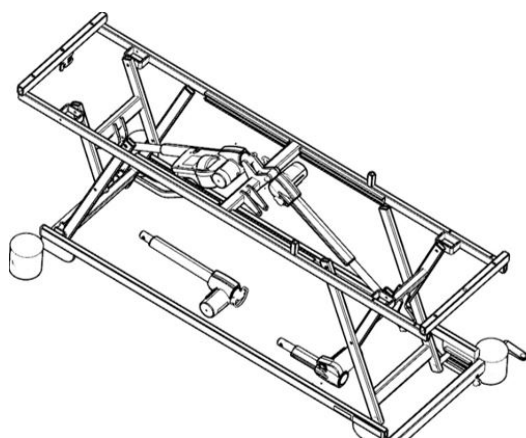

5. Put the mattress base in place.

Note: Pay attention to the signs indicating the head and foot end.

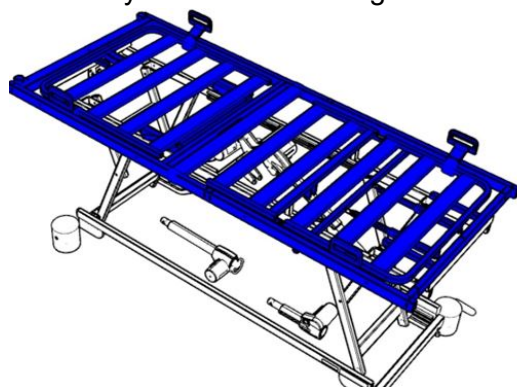

6. Insert the location pins [1] into the holes on both sides.

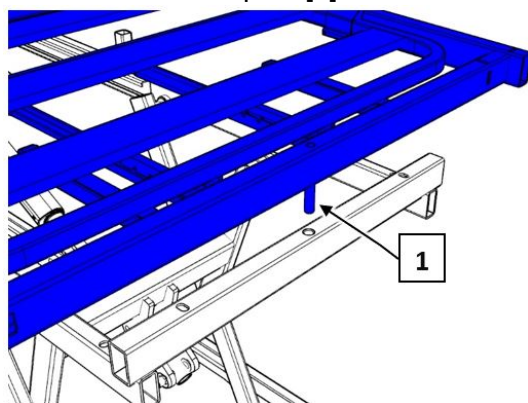

7. Connect the mattress base and the chassis [2] with the handwheel bolts (2 x 2 bolts).

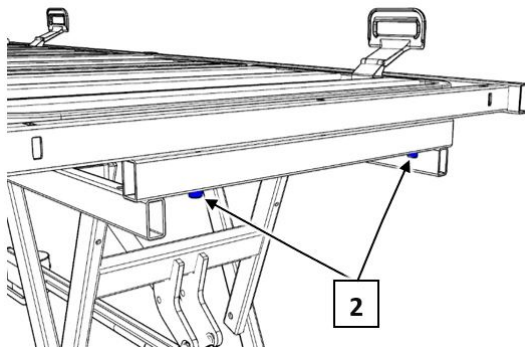

8. Raise the backrest by hand.

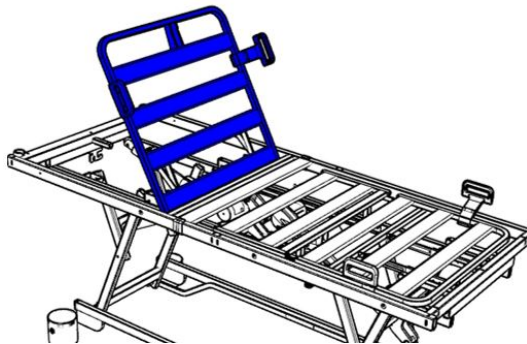

9. Insert the backrest motor into the take-up and secure it in place with the locking pin [3] on the housing side.

Note: Observe the following installation position. The housing assembly must be located over the lift motor.

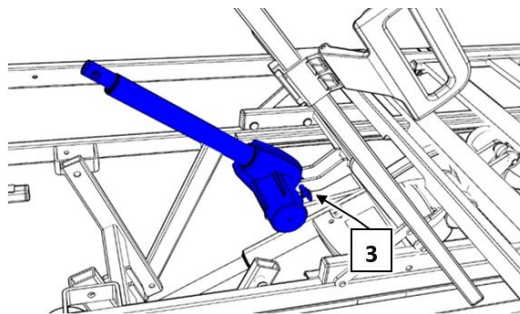

10. Guide the lifting bar for the backrest motor into the take-up.

11. Secure the lifting bar with the locking pin [4].

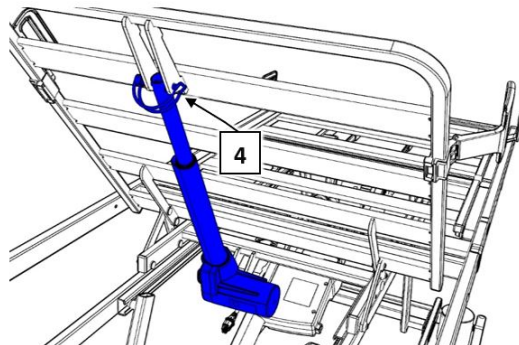

12. Raise the thigh rest.
13. Place the thigh rest motor in the take-up.
14. Secure the thigh rest motor in place on the housing side using the locking pin [5].
Note: Observe the following installation position. The housing assembly must be located over the lifting motor.

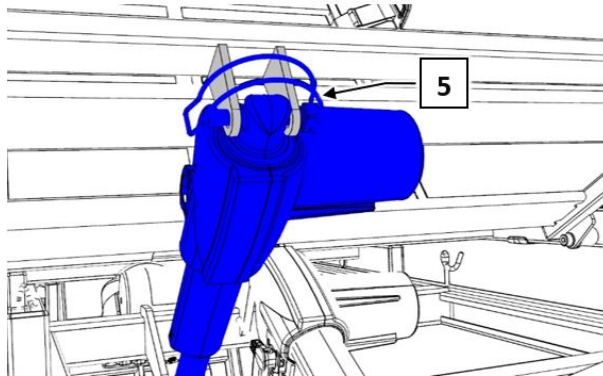

15. Guide the lifting bar for the thigh rest motor into the take-up.
16. Secure the lifting bar with the locking pin [6].

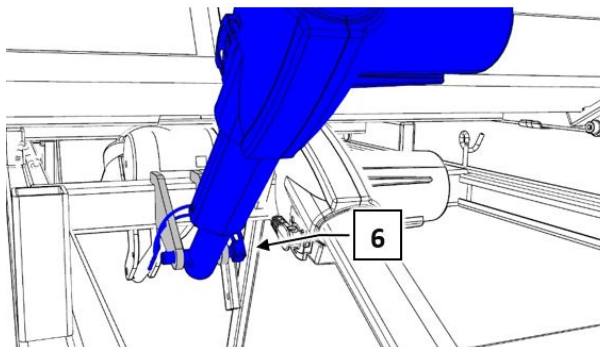

3.4 Headboard and footboard

As an optional feature, the headboard and footboard can be quickly fitted/removed without tools to provide easier access to the resident. The headboard and footboard are fitted/removed by operating a locking lever that is attached to the cross tubing.

WARNING

Risk of injury

Failing to heed this warning may result in physical injuries due to entrapment or falling caused by incorrect assembly/storage of split safety sides/headboard and footboard/side panels with Easy Switch system!

- Please carefully follow the assembly steps described below.

- After assembly, carry out the mandatory checks to make sure that the fixings are secure.
- To ensure that the plastic locking levers of the “Easy Switch” system function properly, do not allow them to fall or suffer severe knocks during disassembly or storage.
- Never use “Easy Switch” systems that are damaged.

3.4.1 Attachment

 Similar to illustration!

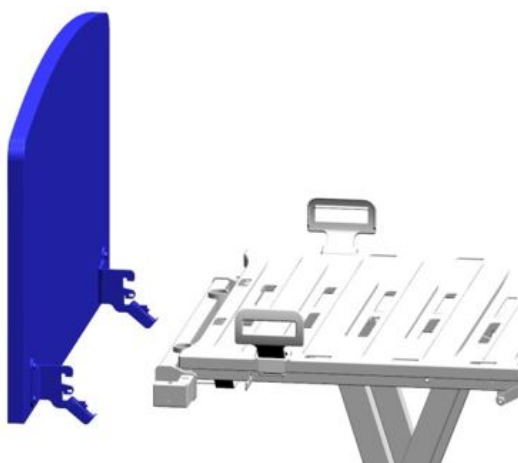

1 Standing behind the headboard/footboard, firmly grip the uppermost corners of the headboard/footboard with both hands

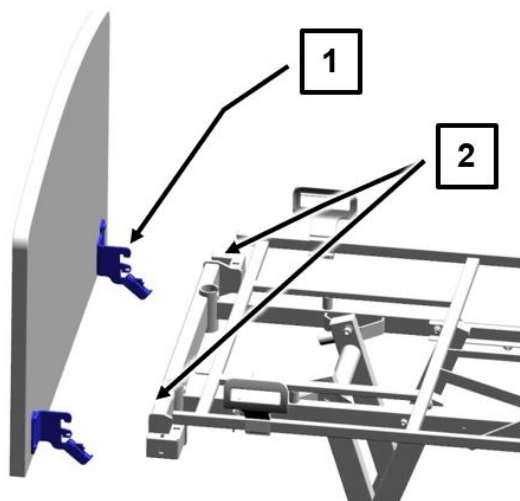

2 Insert the locking hooks [1] of the adapters as far as they will go into the slits of the cross tube [2] and make sure the headboard/footboard is fitted securely

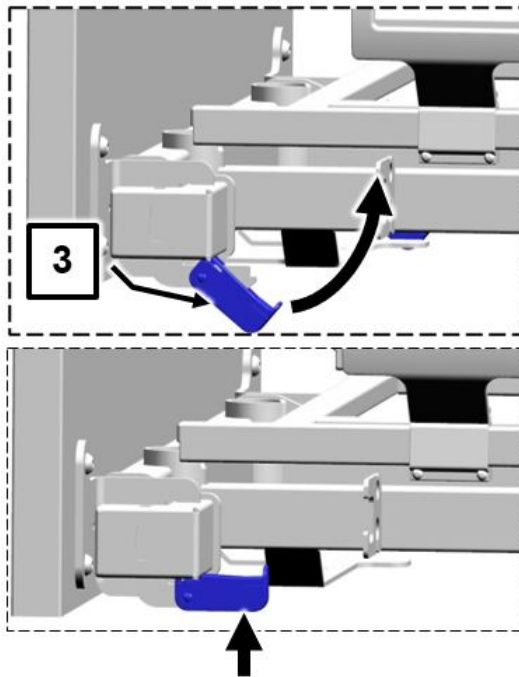

3 Swivel the locking levers [3] (left and right side) upwards and press until they audibly click into place

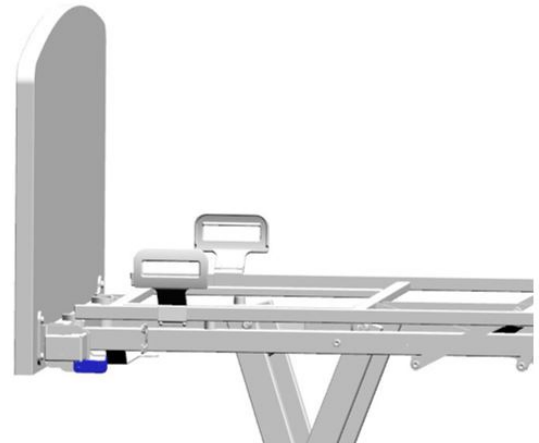

4 Check that the headboard/footboard is firmly in place by pulling the top edge of the board to and fro

3.4.2 Removal

 Similar to illustration!

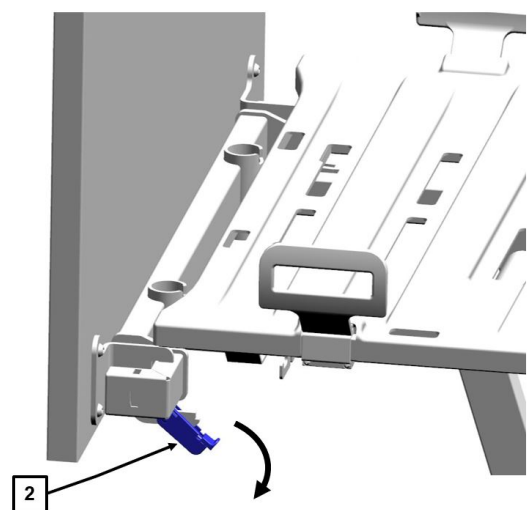
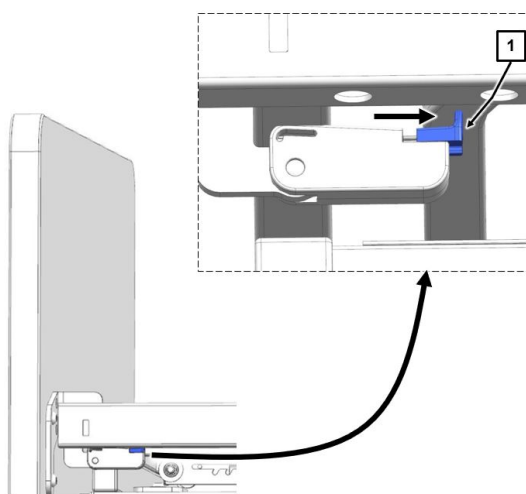

- 1 Use a finger to pull the orange safety lock [1] towards the centre of the bed and keep holding it in this position.

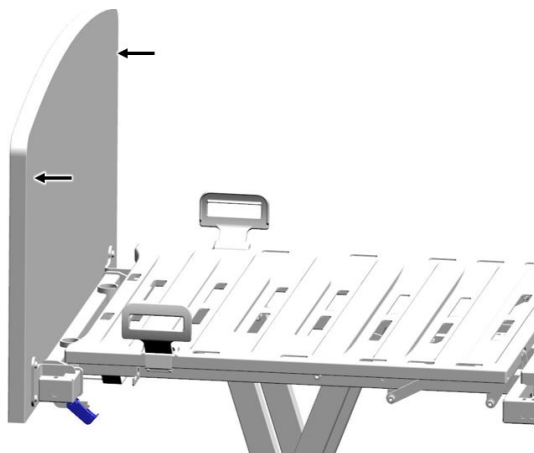

- 2 Swivel the locking levers [2] (left and right side) downwards.

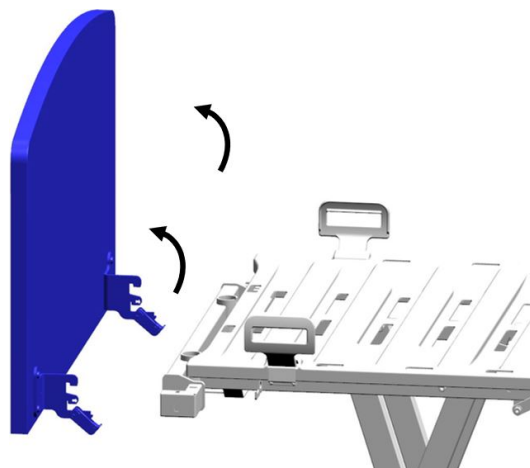

- 3 Standing behind the headboard/footboard, firmly grip the uppermost corners of the headboard/footboard with both hands.

- 4 Pull the headboard/footboard straight up and then outwards out of the slits in the cross tube, as evenly as possible.

3.5 Side panels

3.5.1 Split side panels

The bed can optionally be fitted with side panels. A total of four side panels are needed: 2 x long (110 cm) and 2 x short (90 cm). 1x short and 1x long side panel are mounted on each side of the bed. When fitting a bed extension at a later date, the short side panels must be replaced with longer ones.

WARNING

Risk of injury

Failure to heed this warning may result in entrapment or falls due to incorrect assembly/storage of split safety sides/headboard and footboard/side panels with “Easy Switch” system!

- Please carefully follow the assembly steps described below.

- After assembly, carry out the mandatory checks to make sure that the fixings are secure.
- To ensure that the plastic locking levers of the “Easy Switch” system function properly, do not allow them to fall or suffer severe knocks during disassembly or storage.
- Never use “Easy Switch” systems that are damaged.

3.5.1.1 Attachment

Fit the side panels by simply clamping them onto the long tube.

1. First swivel the locking levers (left and right) for the side panel [1] downwards. To do so, pull the orange safety lock [2] outwards with your finger and hold it in this position while swivelling the locking lever downwards.

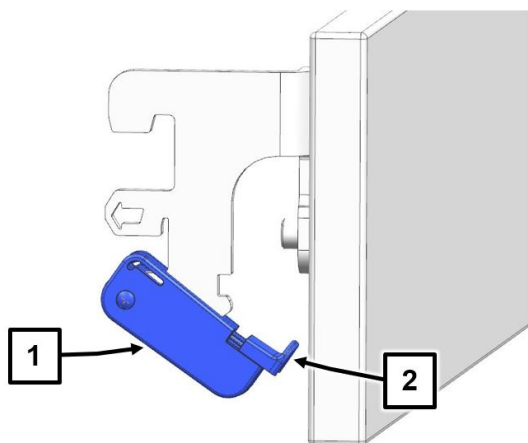

2. Attach the side panel for the head end to the long tube (head end) as shown.

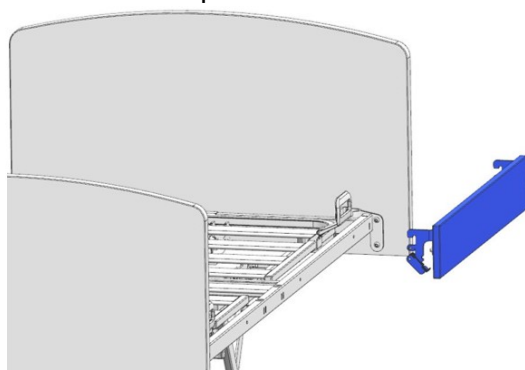

3. Insert the locking hooks for the adapters [1] into the slits in the long tube as far as they will go. Make sure that the panel is fitted securely in place (by visual inspection and by shaking it slightly).

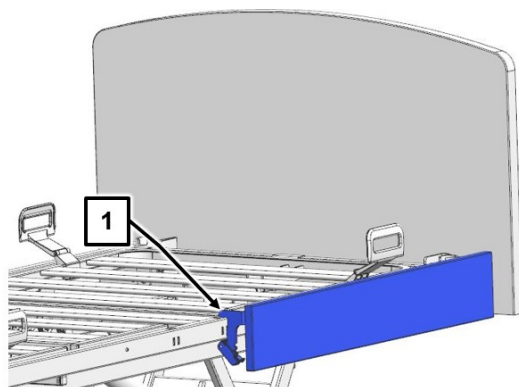

4. Swivel the locking levers [2] (left and right side) upwards and press until they audibly click into place.

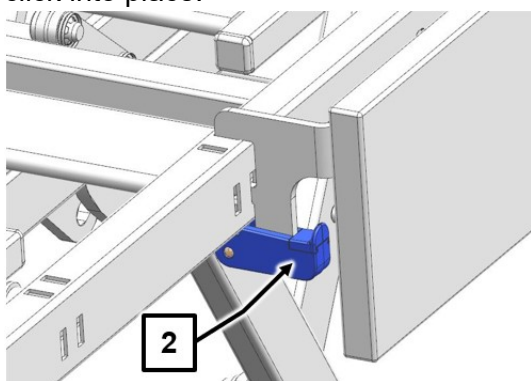

5. Check that the side panel is firmly in place by jiggling the top edge of the panel to and fro.
6. Repeat steps 1 to 5 with the remaining three side panel sections.

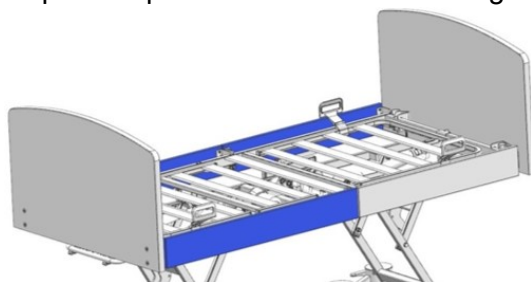

3.5.1.2 Removal

Loosen the locking levers to release the side panels.

1. Use a finger to pull the orange safety lock of the locking lever [1] outwards and keep holding it in this position.

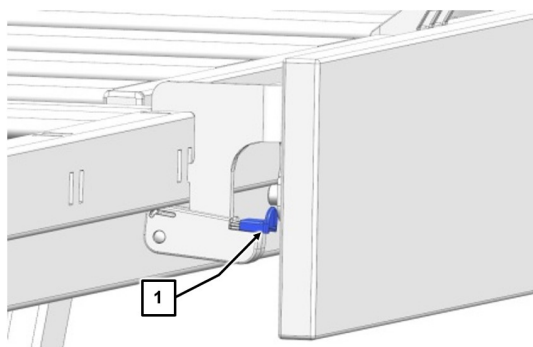

2. Swivel the locking levers [2] (left and right side) downwards.

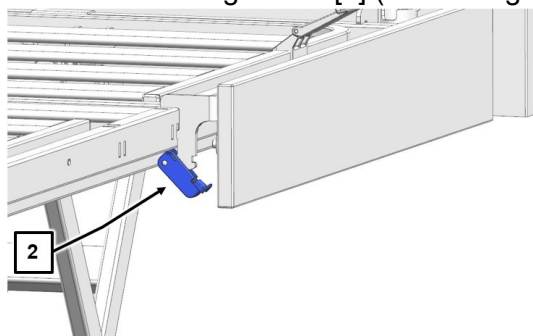

3. Grasp the lower edge of the side panel with both hands.

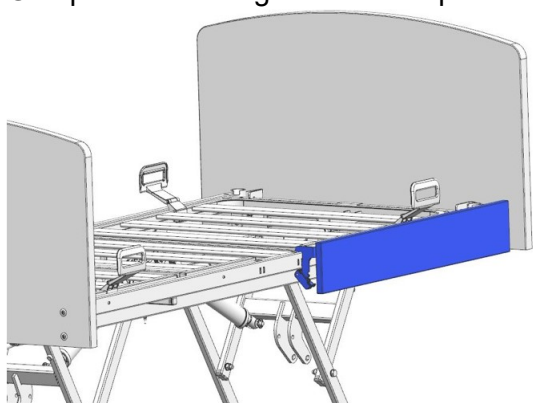

4. Pull the side panel, as smoothly as possible, straight up and then outwards out of the slits in the tube.

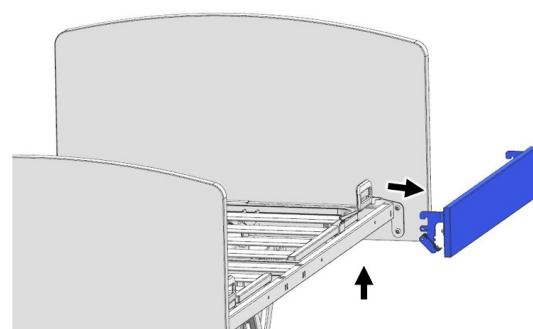

3.5.2 Full-length side panels

The bed can optionally be fitted with full-length side panels (1x per bed side). The use of full-length side panels is only possible in conjunction with full-length safety sides (DSG).

3.5.2.1 Attachment

The side panels are fixed to the longitudinal tube of the mattress base using screws.

 The side panel is asymmetrical. The short side must face upwards.

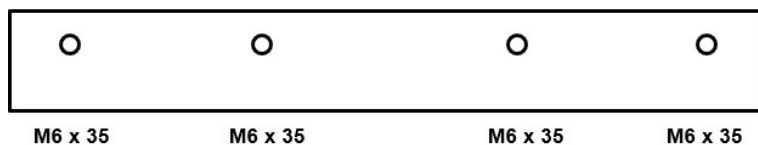

1. Adjust the bed to its highest position to make the assembly process easier.
2. Raise the thigh rest and the backrest.
3. Position the side panel, as shown, along the longitudinal tube of the mattress base [1].

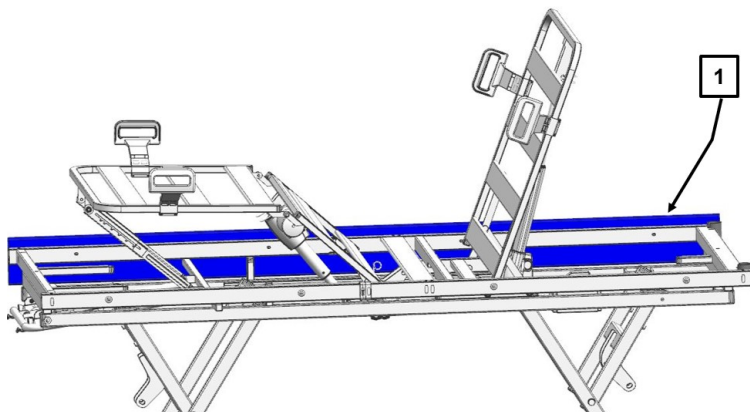

4. Fasten the side panel to the inner side of the mattress base [2] with the through-bolts and the washers (4x).
5. Repeat steps 3 and 4 for the other side panel.

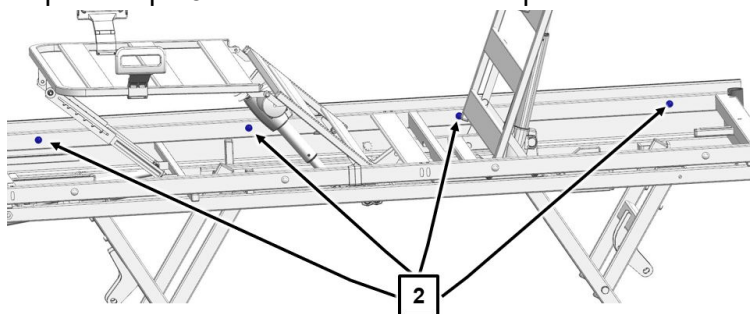

3.5.2.2 Removal

Proceed in reverse order to the attachment process.

3.6 Safety sides

WARNING

Risk of injury

Failure to heed this warning may result in physical injury due to falling from the bed.

- Use only the safety sides described in this manual. Safety sides are either factory integrated into the bed or available as accessories.

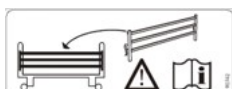

The bed is delivered as standard without any safety sides.

At the customer's request, the bed can be equipped with safety sides to protect the resident from falling out of bed. The safety sides can be raised from the lowered position beside the mattress base to protect the resident.

Should it later be necessary to use a safety side, the bed can easily be fitted with this at a later date.

There are two versions of safety side to choose from:

- Split safety side (TSG)
- Full-length safety sides (DSG)

Type of safety side	Type of mattress base	Height of safety side	Max. mattress height
Full-length safety side	Metal	approx. 41 cm	approx. 19 cm
	Comfort	approx. 37 cm	approx. 15 cm
Split safety side	Metal	approx. 41 cm	approx. 19 cm
	Comfort	approx. 37 cm	approx. 15 cm

3.6.1 No safety sides (standard)

This bed is delivered as standard without any safety sides.

3.6.2 Full-length safety sides (DSG)

The bed can be equipped with full-length safety sides at the customer's request to protect the resident from accidentally falling out of bed. The safety sides are made of bars with plastic end caps and are attached to the bed with a simple click-on system. Whenever the safety sides are needed, they can be raised or lowered by hand by carers or relatives. Each headboard and footboard is fitted with a guide rail on the right and left-hand side. There is a safety side guide in each of these with two fixtures for holding the safety side bars. The safety side guides are pre-assembled at the factory. The safety side bars can be attached to the holding devices quickly and with little effort thanks to the simple click-on system.

3.6.2.1 Installation

CAUTION

Risk of injury

Failure to heed this warning may result in injury and damage to property due to improperly assembled, falling safety side bars.

- After installing each safety side bar, check that it is correctly locked into the holding devices.
- Test the function to check that the safety sides are correctly fitted. For more information on operating the safety sides, see chapter [Part C: Safety sides](#) » [20](#).

 The use of full-length safety sides is only possible with head and footboards that have integrated guide profiles.

Important: The holding devices must be diagonal to each other before starting the assembly work (see picture). To ensure this, raise the holding device at the head end and lower the holding device at the foot end.

1. Start with the headboard on the right-hand side of the bed and proceed as follows: Attach one end of the wooden safety side bar to the holding fixture [1].
 - Please note: The recess on the safety side bar must face inwards and the rounded side of the bar must face upwards.

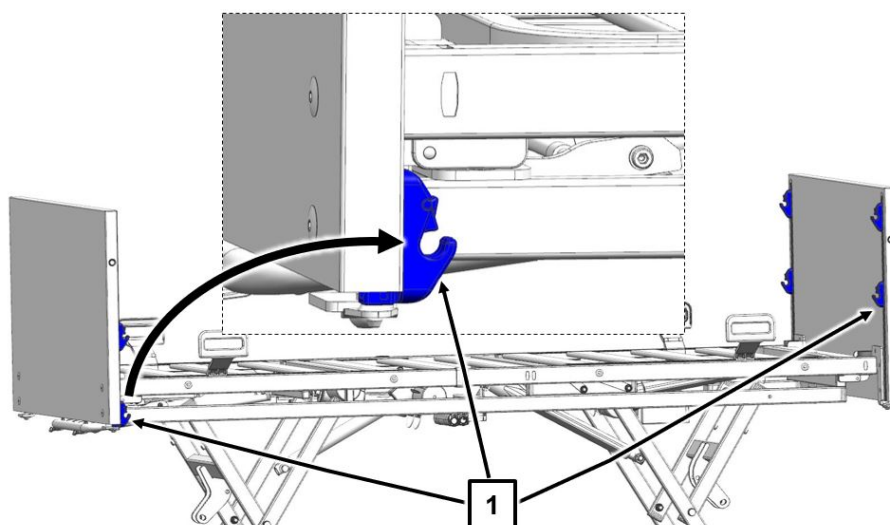

2. Insert one end of the bar into the lower holding fixture (at the head end).
3. Insert the other end of the bar into the lower holding fixture (at the foot end).
 - The bar must firmly click into place with the aid of the release button [2].
 - Make sure that the bar is properly engaged by moving it up and down by hand.

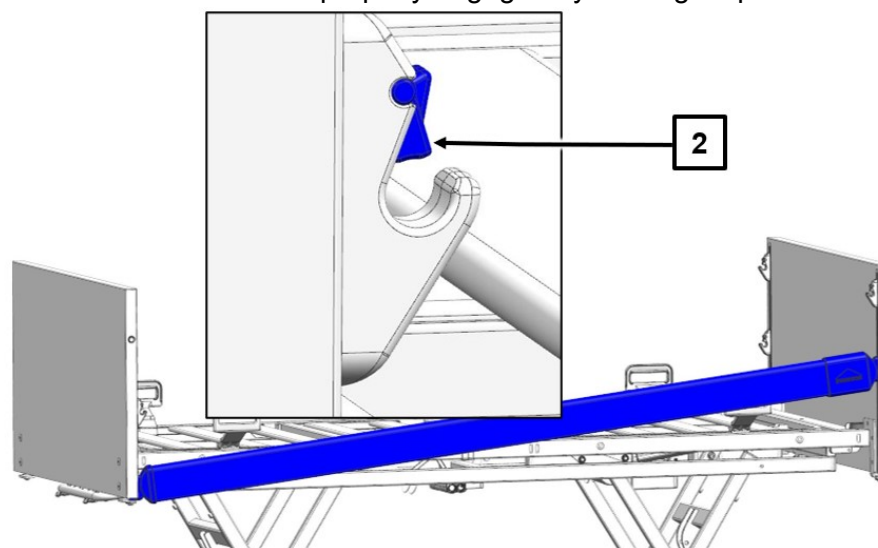

4. Repeat the last few steps to attach the second, third and fourth bars.

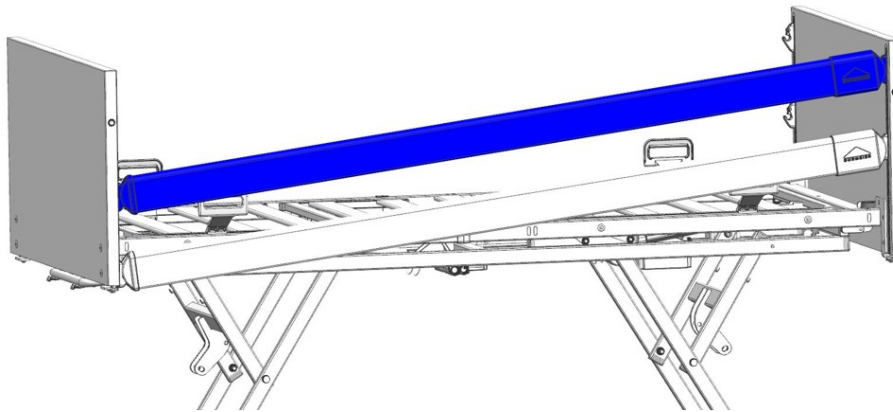

3.6.2.2 Removal

1. Position the safety side bars diagonally as shown.

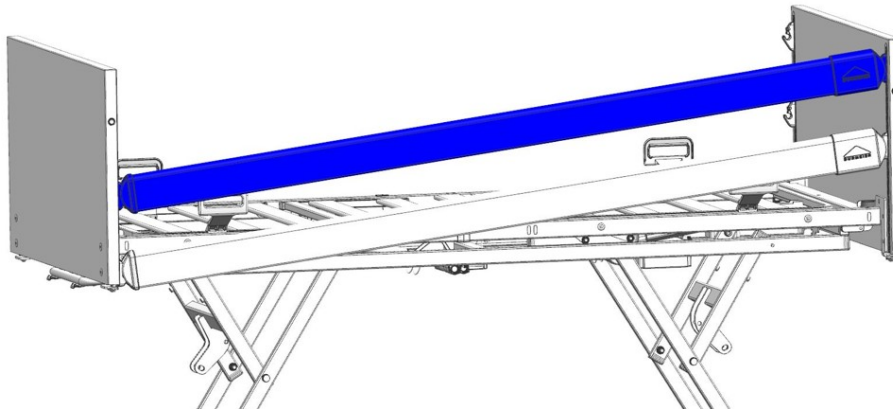

2. Press the release button [2] on the holding device down with your index finger and remove one end of the bar.

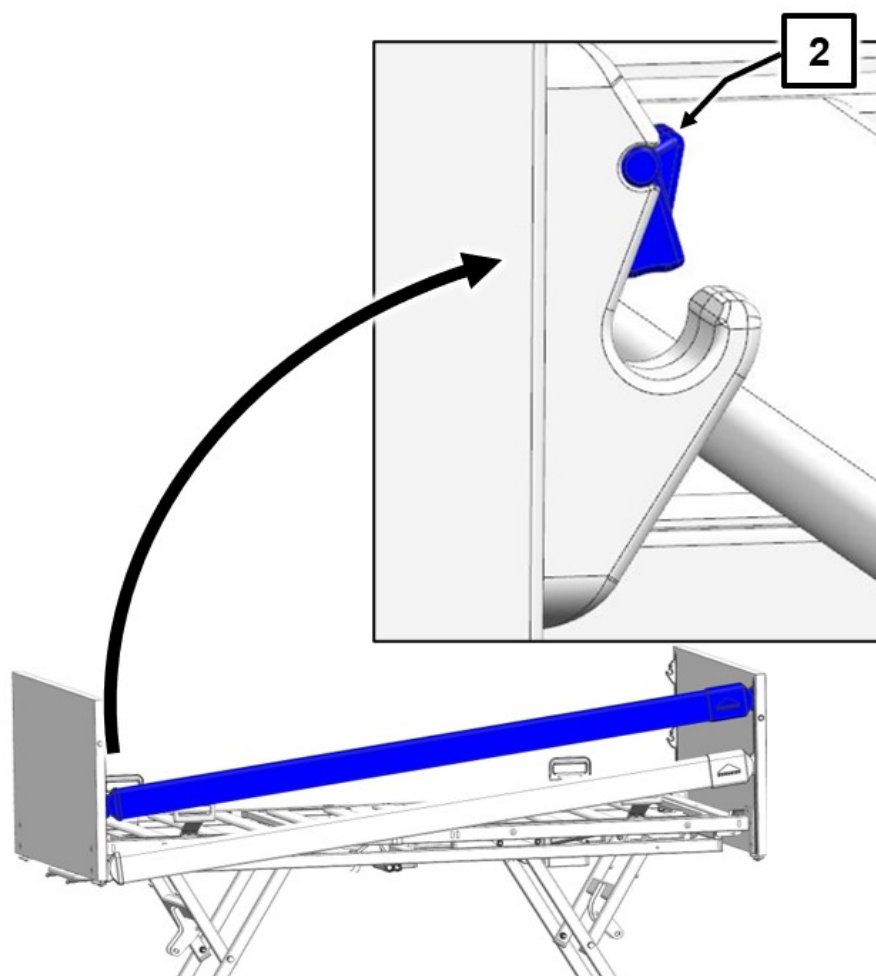

3. Repeat step 2 at the other end of the bar
4. Repeat steps 1 to 3 for the other safety side bars.

3.6.3 Split safety sides

This care bed can also be fitted with optional “Easy Switch” split safety sides.

WARNING

Risk of injury

Failure to heed these warnings may result in injuries due to entrapment or falls, as well as material damage.

- Please carefully follow the assembly steps described below

- After assembly, carry out the mandatory checks to make sure that the fixings are secure.
- To ensure that the plastic locking levers of the “Easy Switch” system function properly, do not allow them to fall or suffer severe knocks during disassembly or storage.
- Never use “Easy Switch” systems that are damaged.

3.6.3.1 Installation

The split safety side (TSG) (Easy Switch) consists of four sections. These simply clamp onto the long sides of the bed to attach them. The safety sides are available in two sizes: 2x long (110 cm) and 2x short (90 cm). One long and one short safety side is fitted to each side of the bed. Start with the long safety side, at the head end on the left-hand side:

- 1 First swivel the locking levers (left and right) of the safety sides [2] downwards. To do so, pull the orange safety lock [1] outwards with your finger and hold it in this position while tilting the locking lever downwards.

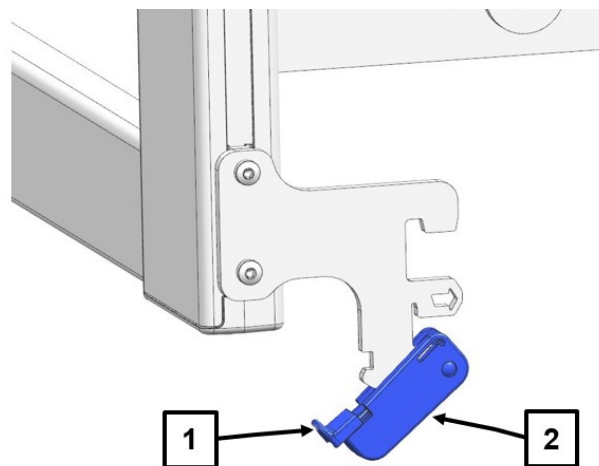

- 2 Attach the safety side to the long bed frame tube at the head end, as shown.

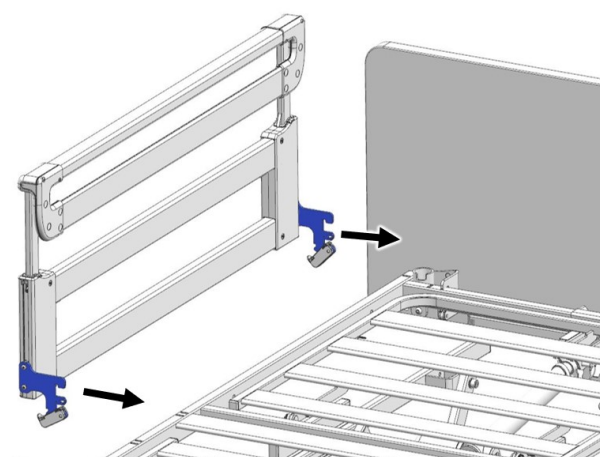

- 3** Insert the locking hooks of the adapters into the slits in the long tube as far as they will go, and ensure that the safety side is inserted properly.

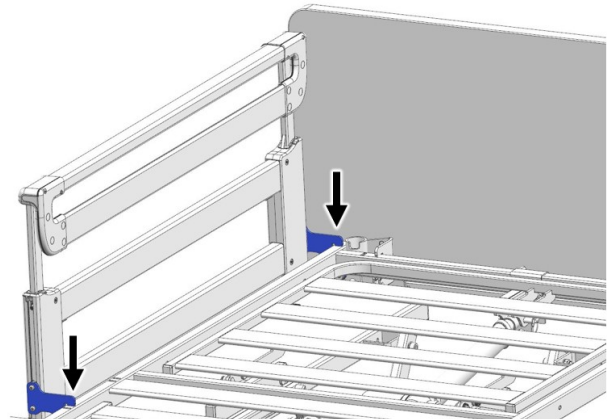

- 4** Swivel the locking levers (left and right-hand side) upwards and press them until they audibly click into place.

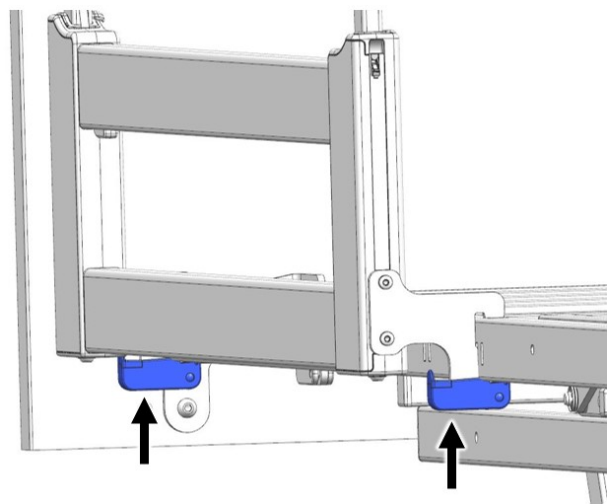

- 5** Check that the safety side is firmly attached by holding it at the lower edge with both hands and trying to move it up and down.

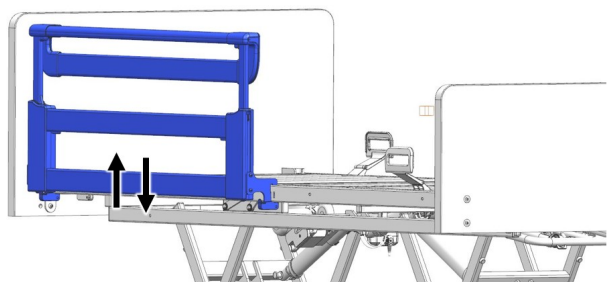

- 6** Repeat steps 1 to 3 with the remaining three sections of the split safety side.

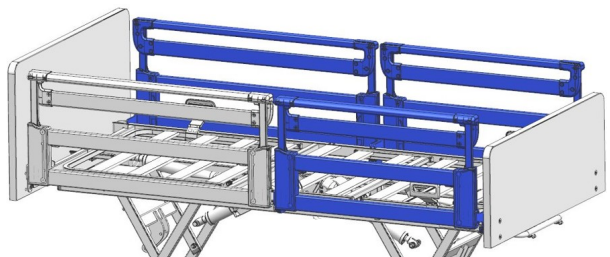

3.6.3.2 Combination of split safety side and side panels

WARNING

Risk of injury

Failure to heed these warnings may result in injury due to the unauthorised combined installation of the split safety side (90 cm wide) and side panel (110 cm wide)!

- Figure A: Short safety side, 90 cm, at the head end, and 110 cm side panel at the foot end: This combination is only permitted as a mobilisation aid to facilitate the entry and exit of residents who do not require increased protection in the form of safety sides to prevent them from accidentally falling out of bed.
- Figures B, C and D: More extensive, standard-compliant protection against accidentally falling out of bed can only be achieved with these variants.

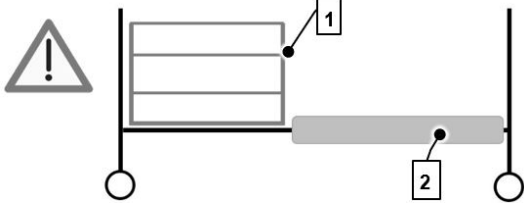
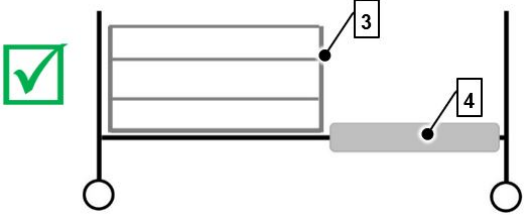
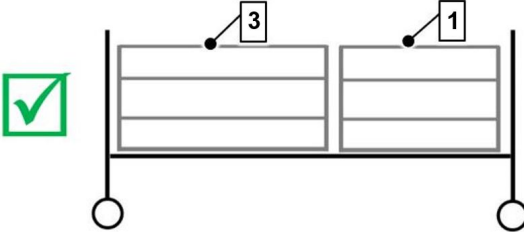
[1]	Split safety side, 90 cm wide	[2]	Side panel, 110 cm wide
[3]	Split safety side 110 cm wide	[4]	Side panel, 90 cm wide
Fig. A			
Fig. B			
Fig. C			

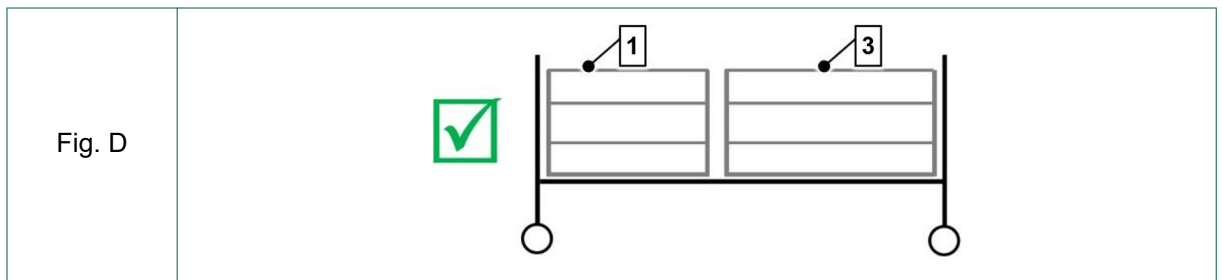

3.6.3.3 Sticker – split safety sides (optional equipment)

WARNING

Risk of injury

Failure to heed this warning may result in physical injury due to entrapment.

- *Please note: There is a sticker in the middle of the long side of the mattress base frame (see illustration). This sticker warns you not to attach two 90 cm long split safety sides to one side of the bed. Doing so creates a gap between the two safety sides, which leads to a risk of entrapment of limbs.*
- Only attach the permitted sizes of split safety sides per bed side (more on this on the next page)
- Observe the following table when installing split safety sides.

	Assembly on beds without a bed extension	Assembly on beds with a bed extension (approx. 20 cm)
Per bed side	1x size 110 cm (head end/foot end) 1x size 90 cm (head end/foot end)	2x size 110 cm

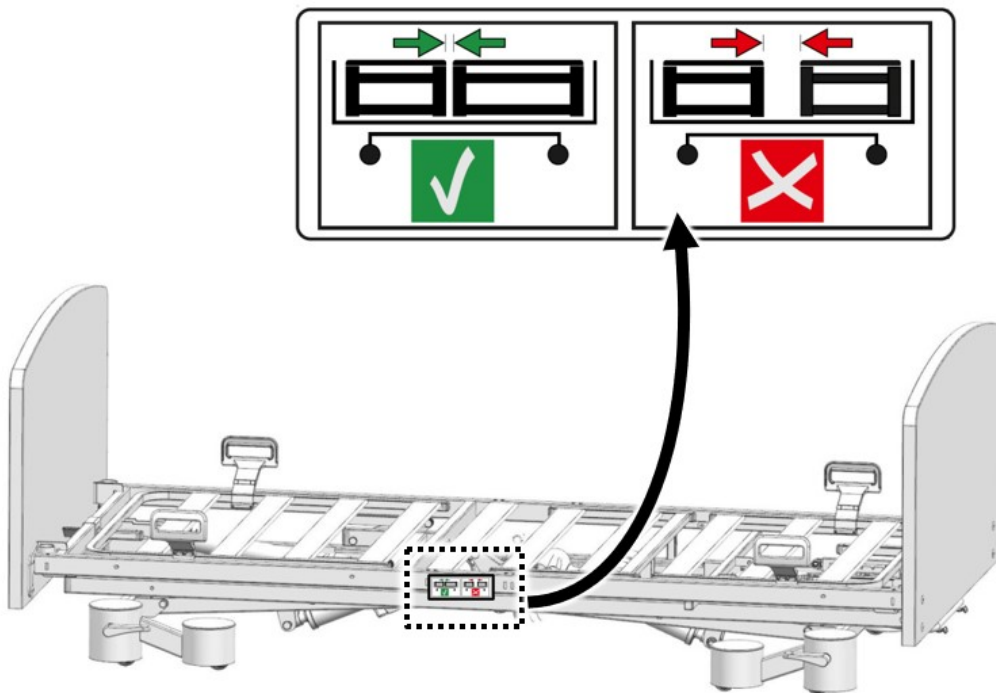

With a bed extension

The following is permitted:

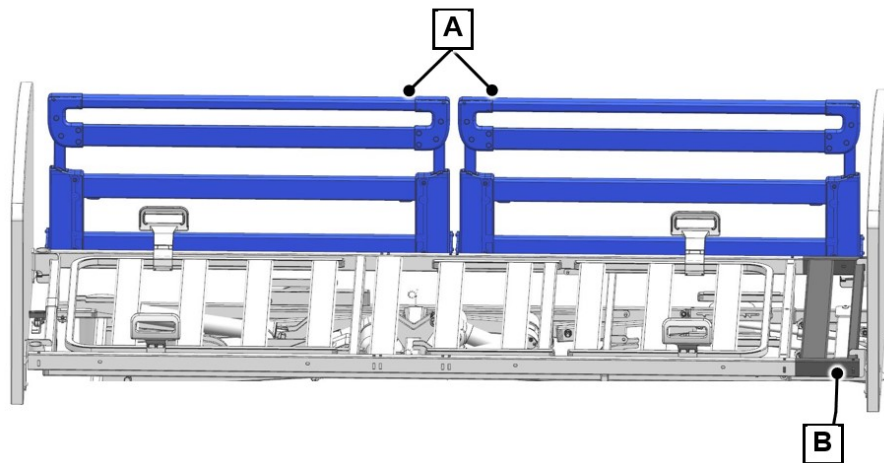

A	2x size 110 cm split safety sides
B	Bed extension approx. 20 cm

Without bed extension

The following is permitted:

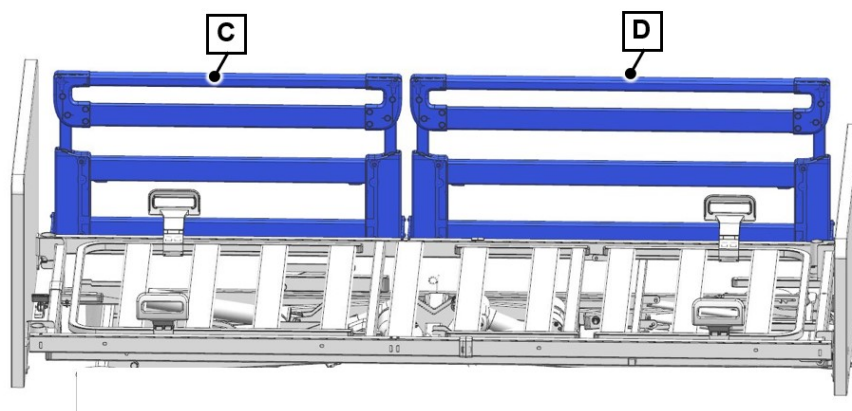

C	1 x size 90 cm split safety side
D	1 x size 110 cm split safety side

3.6.3.4 Covering cap – split safety side

Please note: Slits are provided in the frame of the mattress base to accommodate split safety sides or side panels. Two slits are left open when the large safety side/side panel is mounted at the head end and the small one at the foot end and vice versa. For hygienic reasons, these must be closed with a cover clip [1]. The cover clips are placed over one of the slits before the bed leaves the factory.

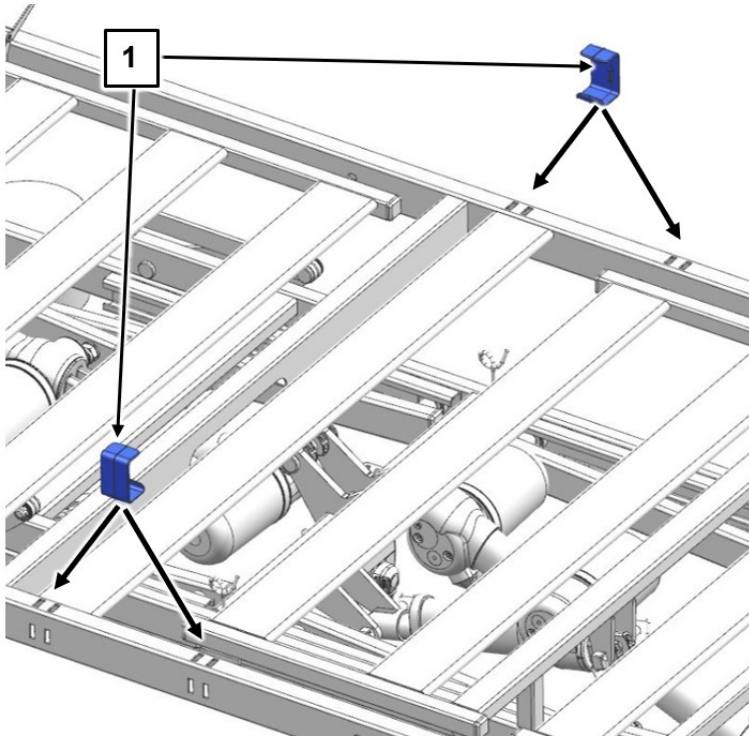

Removing the cover cap

To remove or replace the cover cap, grasp it from below, push it down and remove it from the slit.

Fitting the cover clip

Proceed in reverse order to the removal process.

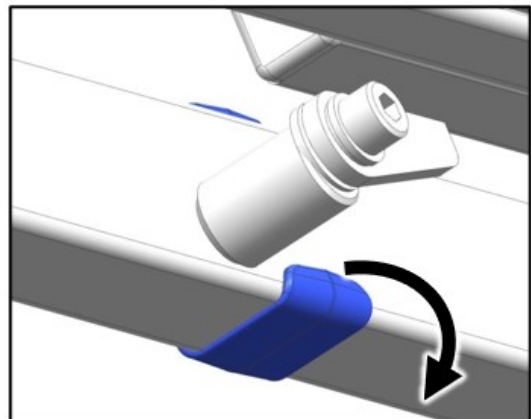

3.6.3.5 Removal

- 1 Use a finger to pull the orange safety lock [1] of the locking lever outwards and keep holding it in this position

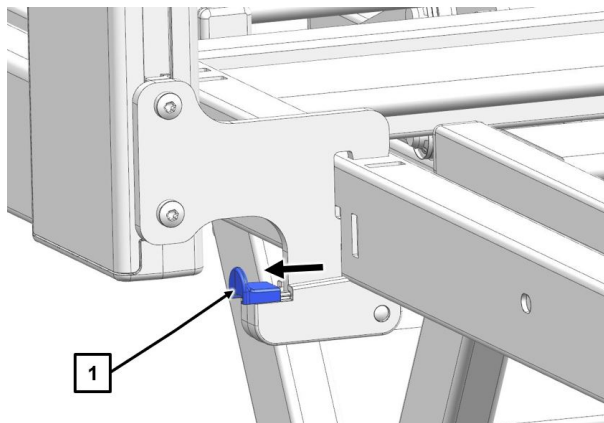

- 2 Tilt the locking levers (on the left and right-hand side) downwards

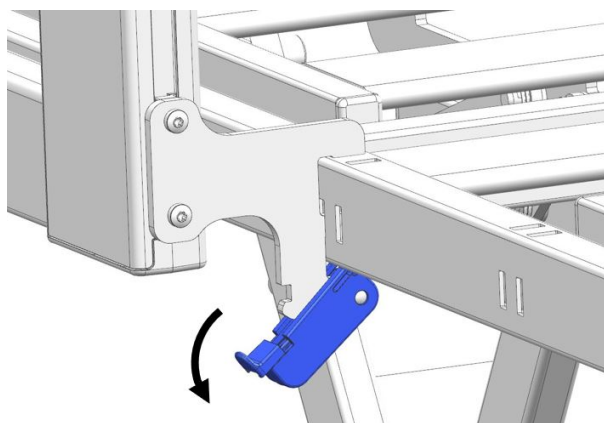

- 3 Hold the safety side by grasping the housing sections at either side with both hands, as shown

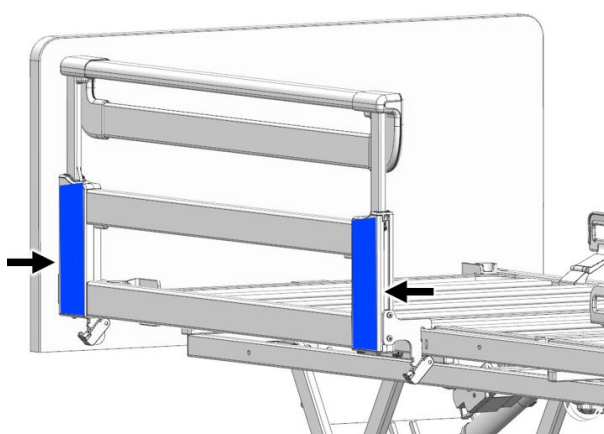

- 4 Pull the safety side straight up and then out of the slits in the long bed frame tube, as smoothly as possible

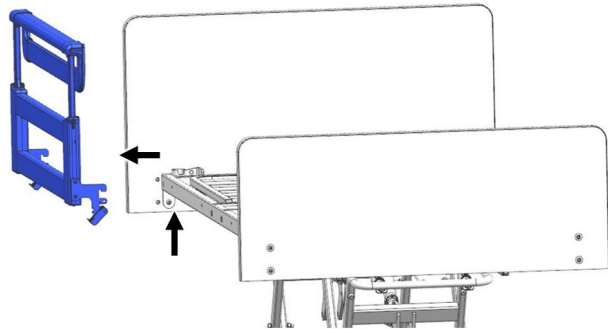

3.7 Adaptable bed extension (option)

The bed can be fitted with an extension at the foot end that extends the length of the mattress base by 20 cm. The free space created is filled with an insert and a mattress piece.

3.7.1 Installation (with split safety sides)

Before extending the bed, observe the following points:

- The bed must not be occupied!
- The bed must be immobilised with the brake.
- The side panel at the foot end must be removed and replaced with a longer one (see [Part B: Side panels » 18](#)).
- The split safety sides (TSG) at the foot end, if fitted, must be dismantled and replaced with longer ones (see [Part B: Split safety sides » 27](#)).
- The bars of the full-length safety sides (DSG) **(8)**, if fitted, must be dismantled and replaced with longer ones (see [Part B: Full-length safety sides \(DSG\) » 24](#)).

Proceed as follows:

1. Remove the footboard (see [Part B: Headboard and footboard » 15](#)).
2. Insert the bed extension into the long tube of the mattress base as far as it will go.

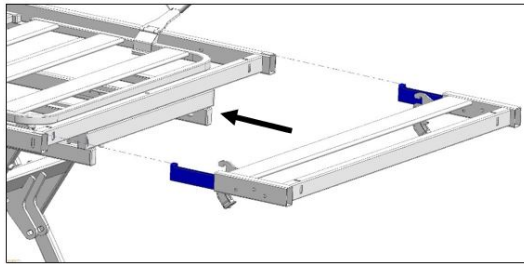

3. Slightly raise the bed extension and push it forwards until the locking hooks on the bed extension slide over the cross tube on the mattress base frame and are positioned over the slits provided [A].

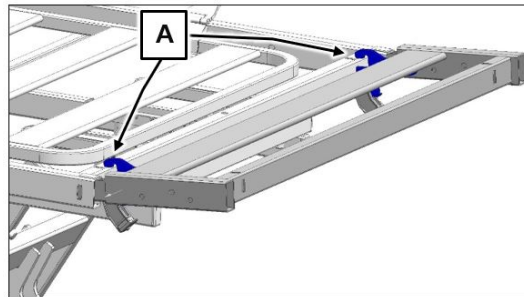

4. Press the bed extension down until the hooks snap into place.
5. Swivel the locking levers upwards (on the left and right-hand side) and press them in until they audibly click into place
6. Install the footboard (see [Part B: Headboard and footboard » 15](#)).
7. Install the longer side panel and/or longer safety side (see [Part B: Side panels » 18](#) and/or [Part B: Full-length safety sides \(DSG\) » 24](#)/[Part B: Split safety sides » 27](#)).

3.7.2 Removal

Proceed in reverse order to the installation process with the only difference: Pull the orange safety lock [C] outwards with your finger and hold it in this position while tilting the locking levers downwards [D].

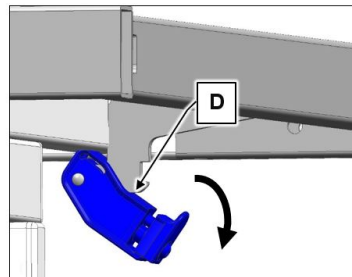
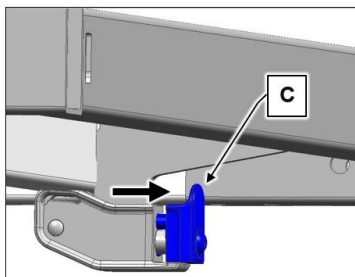

3.8 Comfort mattress base (optional)

Regia can optionally be fitted with a comfort mattress base. The following assembly instructions refer to the 90 cm and 100 cm wide mattress base:

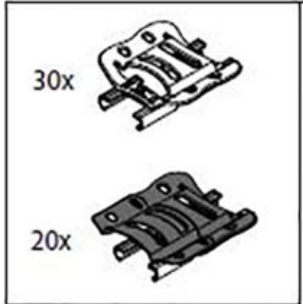
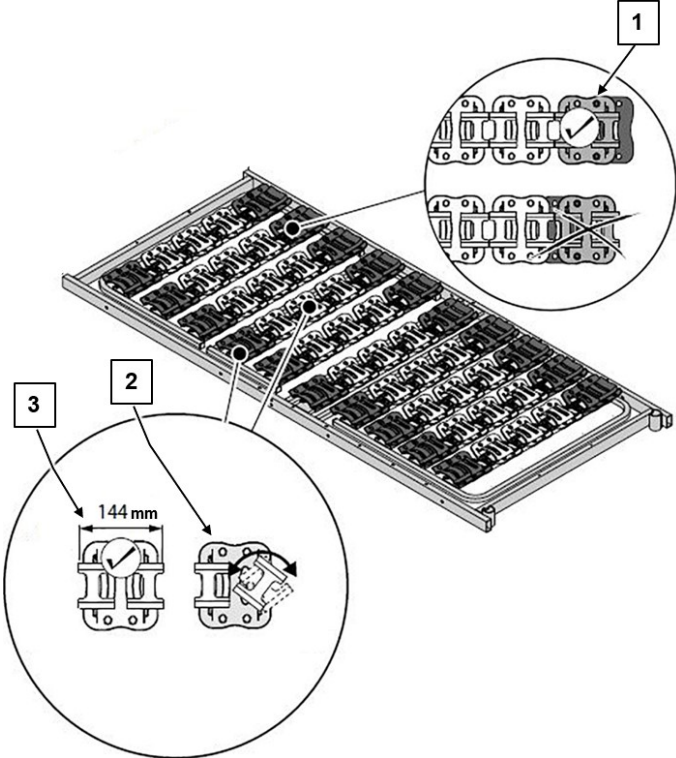
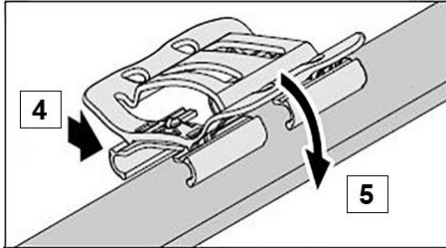
<p>Included in the package:</p>	
<p>1 Wings of the black elements face outwards [1].</p> <p>2 Turn the mounting clips [2] 180° until they are 144 mm in length [3].</p>	
<p>3 Fit the mounting clips onto the struts of the mattress base [4] and [5], white elements in the middle and black elements outside.</p>	

3.9 Electrical connection

- When connecting components, always ensure that the plugs are inserted fully into the control unit. This is the only way to ensure proper sealing and faultless operation.
- Ensure that the plug cover is always on the control unit.
- Stow the motor cable and handset cable under the mattress base frame in such a way that there are no loops and they will not be damaged by moving parts of the bed. Use the cable routing provided on the chassis for this purpose.
- Please take extra care when laying the switch mode power supply connection cable. This cable must not be damaged by moving bed parts or trapped under the castors when moving the bed!



ATTENTION

Material damage

Failure to heed this warning may result in irreparable faults to the switch mode power supply unit and a short-circuit in the wall socket.

- The mains socket you wish to use for the switch mode power supply must NOT be under the bed. Otherwise, the moving mattress base frame may rip the switch mode power supply out of the mains socket during horizontal adjustments.
- Before moving the bed, always hang the switch mode power supply on the head end chassis using the cable holder. The cable holder is attached to the mains cable.
- Before moving the bed, remember the length of the electrical cable; unplug the power supply cable beforehand.
- Take care when adjusting the height: Maintain a sufficient distance at the side between the bed and the switch mode power supply to avoid damaging it. Use wall deflector rollers if necessary.
- Position the bed so as to allow easy access to the switch mode power supply at all times so that the bed can be disconnected from the mains, if necessary.

All plugs are connected to the control unit. To prevent the plugs from being inadvertently disconnected, they are secured with a locking device.

Only the switch mode power supply must be connected.

Proceed as follows:

1. Plug the switch mode power supply into a mains socket.
 - The cable outlet must hang downwards (see picture).
2. Insert the plug of the low-voltage cable into the connection socket found underneath the head end of the mattress base.

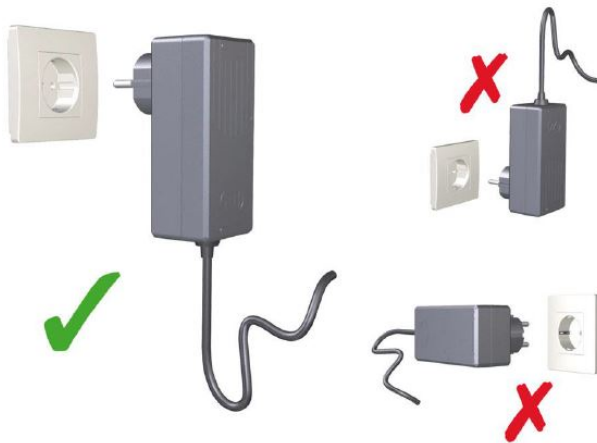

4 Putting into Service

4.1 Putting into service

Before initial operation, no electrical measurement is necessary for beds with a 24-volt system, since these beds are tested for electrical safety and functionality by the manufacturer before they leave the factory in perfect condition.

4.2 Making Ready for Operation

- Allow the bed to adjust to room temperature for about 20 minutes if it was stored beforehand at the lowest or highest permissible temperature.
- After the bed has been assembled, carry out a check in accordance with the chapter [Part B: Maintenance](#) » 47.
- Clean and disinfect the bed before it is used for the first time and before every re-use in accordance with the chapter [Part B: Cleaning and Disinfection](#) » 42.
- The bed is ready for operation if all the steps described in the chapter [Part B: Assembling the Care Bed](#) » 10 have been read and carried out successfully.

Before putting the bed into service each time, the user must check that:

- The bed has been cleaned and disinfected.
- The castors are braked.
- The power supply is compatible with the bed (AC 230 V, 50/60 Hz, -15% - +10%).
- The switch mode power supply is connected and the cable is routed in such a way that it cannot be damaged.
- The switch mode power supply, drive cables and handset cable cannot be damaged by moving parts of the bed.
- No obstacles such as bedside cabinets, supply rails or chairs will inhibit adjustments.
- All adjustments function properly and have been checked (see [Part B: Inspections and Function Checks](#) » 48).

The bed must not be put into operation unless these checks have been carried out!

5 Cleaning and Disinfection

5.1 Safety information on cleaning and disinfection

Cleaning is the most important measure and requirement for ensuring successful chemical disinfection.

When the bed is occupied by the same resident, routine cleaning of the bed is generally sufficient.

Disinfection of the chassis is only necessary if it has been visibly contaminated with infectious or potentially infectious materials (blood, stool, pus etc.) or if the doctor requires this due to the presence of an infectious disease.

Before a new resident occupies the bed, the bed must first be cleaned and disinfected by wiping!

ATTENTION

Material damage

Failure to heed this warning may result in severe damage to the bed and its electrical equipment and lead to subsequent faults.

- This bed is not suitable for machine washing or for cleaning in a decontamination unit. The bed is only suitable for manual cleaning and disinfection.
- Unplug the power plug and store it so that it does not come into excessive contact with water or other cleaning solutions (place in a plastic bag).
- Ensure that all plugs on the bed itself are inserted correctly in the control unit and the drive motors.
- Ensure that none of the electrical components show any signs of external damage; otherwise water or cleaning agents may penetrate the system. This can result in malfunctions or damage to the electrical components.

- Before operating the bed again, ensure that there is no residual moisture on the electrical contacts by drying or blowing on the power plug.
 - The electrical components must not be cleaned with a water jet, a high pressure cleaner or any other similar device! Clean only with a moist cloth (at most with pressure-less splash water)!
 - If you suspect that water or any other form of moisture has penetrated the electrical components, unplug the power plug immediately or do not plug it back into the socket. Label the bed clearly as “out of order” and do not use the bed. Report this immediately to the operator responsible.
-

5.2 Cleaning and Disinfection Plan

- Remove the bed linen and send it to the laundry service.
- Clean all surfaces, including the slatted bed frame and mattress base made of synthetic inserts or a metal lattice base, with a mild and environmentally friendly cleaning agent. This also applies for the handset.
- If the bed has been visibly contaminated with infectious or potentially infectious materials, the bed should be subsequently disinfected by wiping with one of the disinfection media approved by the DGHM (Deutsche Gesellschaft für Hygiene und Mikrobiologie, German Society for Hygiene and Microbiology) which is suitable for the corresponding surfaces. The same applies for all beds with residents who have notifiable diseases according to § 6 of the Infektionsschutzgesetz (IfSG, Protection against Infection Act), bacterial infections, or infections with multiple-resistant pathogens (e.g. MRSA, VRE), as well as all beds in intensive care stations and infectious disease clinics. For all disinfections, the concentrations given in the DGHM list must be observed.
- Disinfection of the castors is only necessary when they have been visibly contaminated with infectious or potentially infectious materials.



Continuous disinfection is only necessary in hospitals when a resident has a multiple-resistant pathogen (e.g. MRSA).

5.3 Instruction of Care Staff and Technical Personnel

In order to ensure that cleaning and disinfection are conducted properly, we recommend that users and staff are appropriately instructed. They should be instructed to observe the following points:

- A clean bed must be transported in such a way that it will not become dirty or contaminated during transport.
- When dismantling the bed, we recommend that it should be cleaned and wiped down with disinfectant straight away. Staff should be informed of the special measures required for cleaning and disinfection and should carry out the procedure in a reliable manner (the operator should specify the operational procedures and the individual procedural steps). Care must be taken that only disinfection agents approved by the DGHM (German Society for Hygiene and Microbiology) are used, and that these are used only in the DGHM-approved concentrations.

The disinfectants must be suitable for use with the surfaces to be disinfected.

- For this activity, staff should be provided with (disposable) aprons and gloves which are impermeable to fluids.
- For cleaning, only fresh, clean cloths may be used which are subsequently laundered.
- When cleaning/disinfecting work has been completed, technical staff must disinfect their hands before carrying out other tasks. Staff should be equipped with a suitable pump dispenser containing a disinfectant for hands.

The immediate cleaning of the bed on site has the advantage that no “dirty” beds or bed components are transported together with clean beds. The transfer of potentially infectious germs that may be on the used bed frame is prevented in this way. A transfer of germs in terms of a nosocomial infection can be safely avoided by consistently and thoroughly following these recommendations.

When the bed is not immediately re-used, it should be stored (covered) in such a way that it is protected from dust, inadvertent dirt and contamination.

5.4 Cleaning agents and disinfectants

Observe the following recommendations to ensure the bed remains fit for use for as long as possible:

ATTENTION

Material damage

Failure to heed this warning may result in damages to the surface of the bed or of accessories.

- Do not use scouring agents, stainless steel care products, abrasive cleaning products or scouring pads. These products can damage the surface.
- Cleaning and decontaminating agents must be used in the specified concentrations.

- We recommend cleaning the bed by wiping it with a (damp) cloth. When selecting cleaning agents, ensure that the agents chosen are mild (gentle to skin and surfaces) and environmentally friendly. A standard household detergent or a cleaning and disinfection agent tested by Burmeier can generally be used. Refer to [Part C: Cleaning agents and disinfectants](#) » [38](#).
- Ensure that no liquid residues remain on any parts of the bed after cleaning or disinfection. Otherwise the surfaces in these areas may become damaged in the long term.
- It is essential to follow the manufacturer's dosage advice for cleaning agents and disinfectants to prevent damaging the plastic and painted or metal surfaces! It is not permitted to clean the bed using a manually operated steel jet nozzle which is, for example, connected to a steam cleaner/high pressure cleaner. A minimum distance of 30 cm from the electrical components cannot be guaranteed in this case.
- If, despite its excellent mechanical resistance, the coated surface is damaged by scratches or marks that permeate the entire coating, the affected areas should be resealed using a suitable repair substance to prevent moisture from penetrating. For further information, consult BURMEIER or a specialist dealer of your choice.
- Disinfectants based on compounds that could potentially release chlorine may be corrosive for metals, synthetics, rubbers and other materials over longer contact periods or when concentrations are too high. Use these agents sparingly and only if expressly required.
- For disinfection by wiping, most cleaning and disinfection agents usually used in hospitals or care facilities can be used, such as cold and hot water, detergents, alkaline solutions and alcohols.
- These agents must not contain any substances that could change the surface structure or the adhesive properties of the plastic materials.

The choice of cleaning agents and disinfectants available on the market may change from time to time. Burmeier therefore routinely tests the most commonly used materials for compatibility. The most up-to-date list of tested cleaning agents and disinfectants can be obtained on request.

Our customer service centre in Germany:

Burmeier GmbH & Co. KG

(A Stieglmeyer-Group company)

Industriestraße 53 / 32120 Hiddenhausen / Germany

Tel.:+49 (0) 5223 9769 - 0 • Fax:+49 (0) 5223 9769 - 090

Email:info@burmeier.com

Internet:www.burmeier.com

Customers outside Germany can contact our distribution companies in their particular country if they have any questions. Contact details can be found on our website.

5.5 Handling Cleaning and Disinfection Agents

- Follow the instructions for use for the particular products and their manufacturer. Pay attention to the exact dosage! We recommend the use of automated dosing instruments.
- Always prepare solutions with cold water in order to avoid the formation of vapours which are mucous membrane irritants.
- Wear gloves, in order to avoid direct skin contact.
- Do not keep ready prepared surface disinfection solutions in open containers with floating cleaning cloths. Be sure to cover all containers!
- Use sealable bottles with pump dispensers for moistening the cleaning cloths.
- Ventilate the room after the disinfection has been completed.
- Disinfect by wiping; do not disinfect by spraying! When spraying, a large portion of the disinfectant is released as spray and could be inhaled.
- Furthermore, the wiping effect plays a significant role.
- Do not use alcohols for the disinfection of large surfaces.

6 Maintenance

6.1 Legal principles

Operators of medical beds in Europe are obliged, in accordance with the new Medical Device Regulation (EU) 2017/745 (MDR) and existing relevant national laws/regulations, e.g. in Germany currently the

- German Medical Devices Operator Ordinance § 4 (Maintenance)
- Berufsgenossenschafts-Vorschrift DGUV regulation 3 (Directive of the German Employers Liability Insurance Association, Testing of mobile electrical equipment in industrial use)

to preserve the safe operating condition of medical devices throughout their entire service life. This also includes regularly carrying out expert maintenance and safety checks.

Beds purchased for private use (non-commercial use) are not subject to regular safety inspections, but these are recommended by the manufacturer.

Information for operators

This bed has been designed and built to work safely over a long period of time. When operated and used properly, the expected service life of this bed is 2 to 8 years. The bed's service life depends on its frequency of use and the conditions under which it is used.

All 'serious incidents' ¹ relating to the device must be reported to the manufacturer and the competent authority of the member state in which the user and/or patient is established (in Germany: www.BfArM.de)

¹: Incident that had, could have had, or could have, one of the following direct or indirect consequences: a) the death of a patient, user or another person, b) the temporary or permanent serious deterioration in the health of a patient, user or another person, c) a serious risk for public health, (source: MDR, Article 2(65))

ATTENTION

Material damage

Failure to heed this note may result in material damage.

- Damage, defects and wear resulting from improper operation and after long-term use cannot be ruled out.
- if they are not recognised and corrected immediately.

To this end, there are legal requirements for conducting regular inspections in order to guarantee the safe condition of this medical product. According to § 4 of the Medical Devices Operator Ordinance (Medizinprodukte-Betreiberverordnung) it is the responsibility of the operator to maintain this product. For this reason, the following regular inspections and function checks must be carried out by the operator.

In other countries outside Germany or the EU, the relevant national regulations must be complied with.

The operator is furthermore obliged to instruct care staff about the maintenance work that they must perform. Maintenance work that must be carried out by care staff is described in the chapter [Part C: Maintenance](#) » [35](#).

6.2 Inspections and Function Checks

The operator of this care bed is obliged according to MPBetreibV (Medical Devices Operator Ordinance) Section 4 to conduct regular inspections after each renewed assembly, after each maintenance and during regular operation to ensure the safe condition of the care bed.

These inspections must be repeated within the regular maintenance activities depending on the conditions of use according to MPBetreibV § 4 and the inspections prescribed by the Employers' Liability Insurance Associations for mobile electrical equipment in commercial use according to DGUV regulation 3 (Testing of Mobile Electrical Equipment in Commercial Use).

All servicing and maintenance measures must be carried out when the bed is unoccupied.

- Observe the following order of inspection according to DIN EN 62353:
 1. Visual inspection
 2. Electrical measurement
 3. Functional check
- In accordance with § 4 MPBetreibV, the performance test and the evaluation and documentation of the test results must only be performed by an expert with the relevant knowledge and experience required to perform them properly.
- The Electrical Measurement Procedure according to DIN EN 62353 may also be conducted by electrically instructed persons [in the sense of DGUV regulation 3] with additional medical and device-specific know-how if appropriate measuring instruments are present.
- The test results must be evaluated and documented only by a qualified electrician with additional medical and device-specific expertise.
- Electrical measurements include a leakage current test of the external switch mode power supply, and not the bed itself. As a result, the bed is ready for operation immediately after the switch mode power supply has been replaced with an intact switch mode power supply.
- Burmeier offers leakage current testing of switch mode power supply units as a service. To take advantage of this, the power supply units must be sent to Burmeier. You will receive tested switch mode power supply units in return. Contact us for further details about this; refer to [Part B: Replacement parts](#) » [55](#) for the address.

6.2.1 Operating Current Test Procedure

Preparation

- Unplug the switch mode power supply from the electrical socket.
- Unplug the 24-volt power supply cable from the socket.
- Insert the plug of the 24-volt cable into the measuring adapter (special accessory, available from Burmeier on request).
- Connect the measuring adapter to the “test probe” or similar socket of the test device.
- Plug the switch mode power supply into the test socket on the test device.

Test procedure:

- Leakage current test: direct or differential current in accordance with DIN EN 62353
- Perform a leakage current test in accordance with the instructions provided by the test device manufacturer.

Limit value:

- Leakage current I Ablsmaller than 0.1 mA.

Inspection cycle:

We recommend an annual inspection and functional check. If this test is passed, electrical measurement every ten years is sufficient.

In the case of verifiable compliance with 2% error rate (see also DGUV regulation 3: §5, Table 1B), the inspection cycle of the inspection and function test can be extended to a maximum of 2 years.

The inspection report templates shown on the pages that follow should be used.

6.2.2 Inspection report

The following is an inspection report template for inspecting electro-medical equipment in accordance with DIN EN 62353 (latest issue):

Inspection report	
Customer / Medical facility / Practice:	
Address:	
Carried out: <input type="checkbox"/> Repeat inspection	<input type="checkbox"/> Inspection prior to initial operation (reference value)
	<input type="checkbox"/> Inspection following repairs/maintenance
Equipment type: <input type="checkbox"/> Hospital bed <input checked="" type="checkbox"/> Care bed	Protection class: <input type="checkbox"/> I <input checked="" type="checkbox"/> II
Bed type: Regia	Inventory number:
Location:	Serial number:
Application environment (IEC60601-2-52): <input type="checkbox"/> 1 <input type="checkbox"/> 2 <input checked="" type="checkbox"/> 3 <input checked="" type="checkbox"/> 4 <input type="checkbox"/> 5	
Manufacturer: Burmeier GmbH & Co. KG	Applied parts: Mattress base, headboard, footboard, safety sides
Testing equipment used (type/inventory no.):	1:
Medical Device Regulation classification: Class I	2:

Inspection report				
I. Visual inspection		OK	Not OK	Description of defect
Visual inspection of the electrical components				
What?	How?			
Stickers and type plates	Present, legible			
Up-to-date instruction manual for the product in question	Present, legible			
Control unit/plug-in power supply housing	Correct position, damage, signs of spilt liquids/contamination that may affect the insulation			
Motor housings and lifting tubes				
Handset: housing and keypad film				
Motor and handset cables	Damage, routing of cable			
Cable harness/switch mode power supply sockets	Available, correct position			
Visual inspection of the mechanical components				
Stickers and type plates	Present, legible			
Patient lifting pole, adapter sleeves	Damage, deformation			
Bed frame	Damage, deformation			
Sprung slats	Damage, splinters			
Castors	Damage			
Mattress base	Damage, deformation			
Wooden surround	Damage, splinters			
Welded seams	Split welded seams			
Safety side bars	Damage, splinters			
Knurled screws	Fixed securely			
Wearing parts, such as joints	Damage			

Inspection report

II. Electrical measurement(Use only measuring instruments according to DIN EN 62353 (VDE 0751-1))

Note: To minimise measuring errors, route the test leads as far away as possible from and not parallel to the power cables and handset cables of the bed. Also observe the operating instructions for the measuring instruments used

Insulation resistance: To be carried out only if there are doubts about the electrical insulation, such as:

If the customer's RCD (residual current circuit breaker) has tripped several times

If defective electrical housings are found and at the same time there are signs of spilled liquids/contamination there that could affect the insulation

1. Plug the mains cable/switching power supply into the test socket of the measuring instrument
2. Connect the probe at the common measuring point of all applied parts: = bare screw of the backrest swivel joint underneath the backrest on the mattress base frame
3. Start the measuring procedure on the measuring instrument; measuring voltage = 500 V DC

	Limit value	Measured value			
Result: Bed prot. class II (type BF)	≥ 70 MΩ	MΩ			
Leakage current (direct or differential current measurement) (type BF)			OK	Not OK	Description of defect
Proceed as follows:					
<ol style="list-style-type: none"> 1. Plug the mains cable/switch mode power supply into the test socket of the measuring instrument. 2. Connect the probe of the measuring instrument to the bed; measuring point: Bare metal screw under backrest in frame of mattress base 3. Operate the motors using the handset for the duration of the measurement 4. Start the measurement procedure on the measuring instrument. 					
	Limit value	Current value			

Inspection report					
		(normalised to rated value of mains voltage)			
Result: Bed prot. class II (type BF)	0.1 mA	mA			
In case of measured voltage external conductor - earth		volt:			

Inspection report				
III. Functional check	OK	Not OK	Description of defect	
Functional check of the electrical components				
What?	How?			
End of travel cut-out of the motors	Automatic cut-out			
External power supply / handset	No 'rattling' when shaken?			
Handset: Operating function, locking function	Perform the test acc. to Part C: Handset » §			
Motors	Abnormal noise development (rattling, uneven running)			
Strain Relief of mains cable (if mains cable available)	Mains cable firmly fastened			
Functional check of the mechanical components				
Joints and pivots	Smooth operation			
Grab handle with strap	Securely fixed when load tested under approx. 75 kg load (hang from it briefly with two hands)			
Castors	Moving and braking			
Emergency release of the backrest	Test according to instruction manual			
Safety sides	Securely engaged, secure position, unlocking			

Inspection report				
Lower leg rest	Engages properly			
Accessories (e.g. patient lifting pole, grab handle)	Correct fastening, no damage, suitable for purpose			
Inspection result:				
Inspection passed; test approval sticker applied:				
<input type="checkbox"/> Safety or functional defects were not detected <input type="checkbox"/> No direct risk, the defects detected can be rectified quickly				
Inspection was not passed; no test approval sticker applied:				
<input type="checkbox"/> Device must be taken out of circulation until the defects have been rectified! <input type="checkbox"/> Device does not conform to requirements – modification/replacement of components/decommissioning recommended.				
All values within permissible range: <input type="checkbox"/> yes <input type="checkbox"/> no			Next inspection date:	
If inspection was not passed:				
<input type="checkbox"/> Defective, do not use bed! => Repair <input type="checkbox"/> Defective, do not use bed! => Take out of service <input type="checkbox"/> Bed does not meet the safety standards				
Test approval sticker applied: <input type="checkbox"/> yes <input type="checkbox"/> no				
Documents that form part of this inspection report:				
<input type="checkbox"/> Enclosure: <input type="checkbox"/>				
Remarks:				
Inspected on:			Inspected by:	Signature:

Inspection report		
Evaluated on:	Operator/ Expert:	Signature:

6.3 Replacement parts

The relevant replacement parts are available from Burmeier, by specifying the item number, order number and serial number. You will find the necessary details by referring to the type plate and the PID number, which is located on the mattress base frame at the head end. For more information, please refer to the chapter [Part A: Type plate » 9](#) and to the chapter [Part A: PID Number » 11](#).

In order to maintain operational reliability and the right to claim under warranty, only original Burmeier replacement parts may be used! To order replacement parts, or make customer service requests or other queries, please contact:

Burmeier GmbH & Co. KG
 (A Stieglmeyer-Group company)
 Industriestraße 53, 32120 Hiddenhausen
 Tel.: +49 (0) 5223 9769 - 0
 Fax: +49 (0) 5223 9769 - 090
 Email: info@burmeier.com

7 Replacement of electrical components

7.1 Safety information

WARNING

Danger of death due to electric shock!

Failure to heed this warning may result in injury due to electric shock.

- Before commencing any work on electrical equipment, always unplug the mains cable from the electrical socket!
- Any work and/or repairs to the electrical equipment may only be carried out by the service engineers, the drive manufacturer or qualified and authorised electricians in compliance with all the relevant VDE and safety regulations!
- On no account should the user attempt to rectify malfunctions in the electrical system!

WARNING

Crushing hazard due to falling mattress base parts!

Failure to heed this warning may result in physical injury due to crushing.

- The bed must be in the home position (with the mattress base horizontal) in order to remove the motors. Otherwise, there is a danger of crushing from falling mattress base sections.
- Before removing drives, secure the affected adjustable bed elements from accidentally falling off (e.g. using suitable support stands).

WARNING

Risk of injury

Failure to heed this warning may result in physical injury due to faulty maintenance.

- All drive components are maintenance-free and must not be opened. In the event of a malfunction, the corresponding components should always be replaced in full!
- When replacing individual components, make sure that the plugs have undamaged O-rings (for sealing) and are inserted into the control unit as far as they will go. This is the only way to ensure proper sealing and faultless operation.
- Ensure the polarity is correct when inserting plugs and do not apply excessive force if the plug does not fit. The plugs have a groove and therefore only fit into the corresponding connection sockets with one polarity.
- Do not wrongly connect the motor connections on the control unit. This can lead to malfunctions or even result in mechanical damage to the drives due to the system not switching off at the end position.
- After replacing the control units and/or the attached drives for adjusting the mattress base height, always initialise the control unit (= re-align the electronic path measurement for these drives). This sets a new reference point in the control unit for correctly measuring the path and avoids faults or damage to the lifting mechanism.



- The plugs for the components are connected to the appropriate control unit. To prevent the plugs from being inadvertently disconnected, they are secured with a locking device. This device can be carefully lifted off using a screwdriver if necessary.
- The control unit sockets should be lightly greased inside with Vaseline. The plugs can then be inserted more easily and the O-rings provide a better seal.
- The locking device must always be properly refastened.
- For information on the connection of various optional electrical components, such as the reading lamp, please refer to the accessory instructions supplied.

7.2 Replace the handset with a new one



In order to reconnect the electrical components correctly after replacement, it is essential to observe the information in the chapter [Part A: Electrical connection diagram](#) » 16.

i The following description applies to the standard handset.

The Trendelenburg handset (optional) can be replaced in the same manner as the standard handset. Please note that the Trendelenburg handset must always be directly connected to the existing distributor box.

- If possible, raise the bed to its highest position to make work easier.
- Unplug the switch mode power supply from the mains socket.
- Track the handset cable to the connecting point on the bed.

For direct connection to control unit

1. Carefully lift the plug cover off the plugs on the control unit using a flat-blade screwdriver.
2. Unplug the handset plug (HB) from the control unit.
3. Plug in the new handset. Make sure that the O-ring on the plug is not damaged. It seals the plug into the control unit.
4. When routing the handset cable, ensure that it cannot be damaged by any moving parts of the bed.
5. Put the plug cover back in place. This prevents all the plugs from being pulled out of the control unit.

For additional features with under bed light or handset extension

For additional features with under bed light or handset extension, the handset may also be connected here and can then be easily replaced:

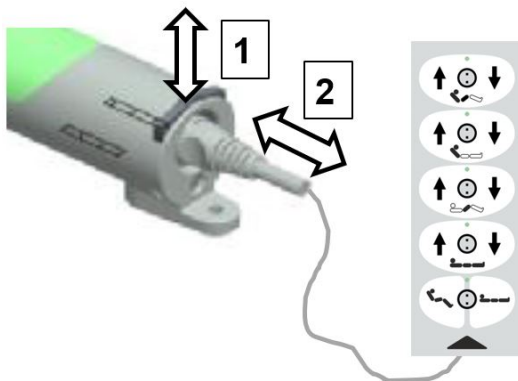

1. **With the handset extension cable:** Open the fastener on the extension cable with your fingers by turning it through 90°.

With the under bed light: Carefully pull out the securing clip [1] slightly using a flat-blade screwdriver. The clip will engage and remain in its raised position.
2. Unplug the handset [2] and plug in a new handset with the plug groove aligned to the socket.

Make sure that the O-ring on the plug is not damaged. This O-ring ensures that the plug is tightly sealed.

3. With the handset extension cable: Turn the fastener through 90° to secure the plug.
With the under bed light: Press the securing clip [1] down as far as it will go.

7.3 Replace the motor

 In order to reconnect the electrical components correctly after replacement, it is essential to observe the information in the chapter [Part A: Electrical connection diagram](#) » [16](#).

1. Unplug the switch mode power supply from the mains socket.
2. Remove the faulty motor.
3. Unplug the plug-in cable connection on the motor.
4. Fit the new motor in the same way.
5. To prevent the motor bolts from working loose and causing potentially hazardous sudden changes in the position of the bed, always ensure that you fit new safety caps (“Starlock”; available from Stieglmeyer’s service department) and do not refit the old safety caps that you removed.
6. Applies only for height adjustment motors: Perform a new initialisation of the control unit; see [Part B: Initialising the control unit](#) » [60](#).
7. After this, check the motorised bed adjustment functions; see chapter [Part C: Handset](#) » [8](#).

7.4 Connecting a reading lamp (optional)

Please refer to the accessory manual supplied for more details.

7.5 Replace the control unit

 In order to reconnect the electrical components correctly after replacement, it is essential to observe the information in the chapter [Part A: Electrical connection diagram](#) » [16](#).

1. Unplug the switch mode power supply from the mains socket.
2. Carefully lift the plug cover off the plugs on the control unit using a flat-blade screwdriver.
3. Mark the plug positions to avoid switching them when they are re-assembled.
4. Unplug all plugs/connecting cables from the control unit.

5. Remove the old control unit from its bracket and fit the new control unit in the same way.
6. Re-insert all plug connections in the corresponding sockets. Make sure that the O-rings on the plugs are present and undamaged. These seal the plugs into the control unit.
7. When routing the handset cable, ensure that it cannot be damaged by any moving parts of the bed.
8. Put the plug cover back in place. This prevents all the plugs from being pulled out of the control unit.
9. Perform a new initialisation of the control unit; see [Part B: Initialising the control unit](#) » 60.
10. Check the motorised bed adjustment functions; see [Part C: Operation](#) » 8!

7.6 Initialising the control unit

This is necessary after installing a new control unit, or when replacing one or both lifting drives of the mattress base height adjustment, or if height adjustment of the mattress base is not possible or only partly possible.

This involves assigning the path impulses of the lifting drives to a reference point by means of a reference run.



The initialisation procedure must be carried out by technical personnel only.

When initialising the control unit, it is important that none of the functions are locked on the handset!

Any restrictions on lowering the mattress base height which have been saved will be lost.

There must be no pauses longer than 6 seconds between the steps without pressing a key. The system will otherwise switch back to the normal operating mode.

Proceed as follows:

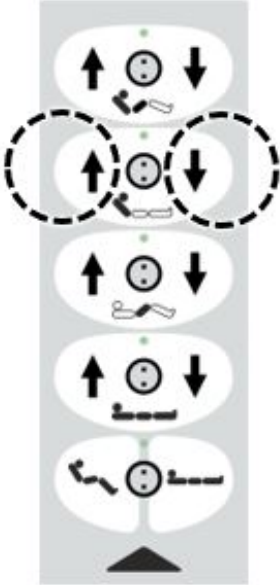
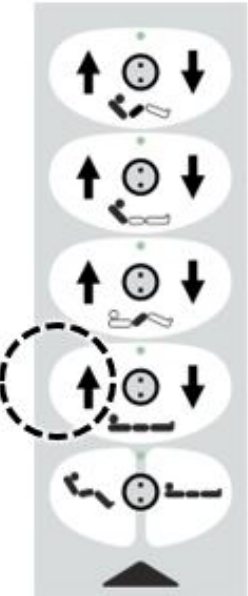
Step	Buttons	Action
1		<p>Press and hold both of the marked keys simultaneously (a rapid intermittent signal sounds) until after approximately 5 seconds a slow intermittent signal sounds (=RESET/ manual mode)</p> <p>Note: When the lift motors are at their end position (top/bottom), the initialisation is complete. Otherwise, follow step 2 below.</p>
2		<p>Raise the mattress base height with the “Height UP” button to the highest horizontal position until both motors switch off automatically at the highest position, and keep the button pressed for a further 2 seconds. When the button is released, the intermittent sound signal stops.</p>

End of initialisation.

If no adjustments are possible and intermittent sound signals sound instead, this means that the control unit has detected a fault and is locked. In this case, reset the control unit (see [Part B: Control unit – Reset » 62](#)).

7.7 Control unit – Reset

Reset the control unit in the following cases:

- If a serious error was detected by the control unit and this has now been properly rectified but the control unit has locked out the affected functions for safety reasons.

Locking can be caused, for example, by:

- A fault in the handset (e.g. a short-circuit/interruption in the cable; a jammed button),
 - A fault in the adjustment motors (e.g. a short-circuit/interruption in the cable, or a fault in the position detection/in the end position switch),
 - An internal fault in the control unit,
- If the module emits intermittent sound signals when making motorised adjustments, and/or no adjustments are possible or adjustments are only possible on one side.

Effect:

- Deletes any existing saved errors (RESET). The last error is retained and can still be read out/displayed.

Proceed as follows:

Press and hold both of the marked buttons simultaneously (a continuous signal sounds) until after approximately 5 seconds an intermittent signal sounds (= RESET/manual mode)

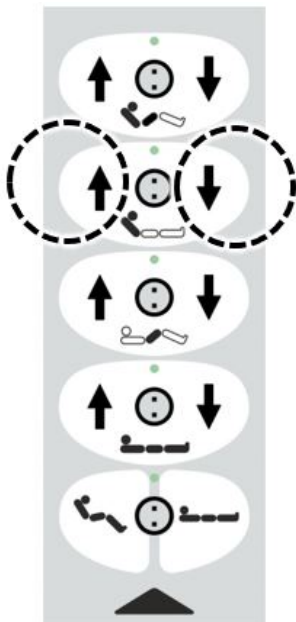

8 Troubleshooting

8.1 Faults and their rectification

Simple faults and problems can often be rectified by trained care staff using the troubleshooting table in this instruction manual. Please refer to the [Part C: Troubleshooting » 31](#). In all other cases, the operator and/or the technical personnel for maintenance and repairs are responsible for rectifying malfunctions and faulty components.

- Please ask care staff to initially try to solve faults and problems with the aid of the troubleshooting table before contacting the operator or technical personnel.

9 Decommissioning

If the bed is not used for an extended period, please follow the instructions below for taking the bed out of service safely and ensuring ideal conditions for its re-use:

- Clean and disinfect the bed (see [Part C: Cleaning and Disinfection » 38](#) or [Part B: Cleaning and Disinfection » 42](#)) and cover it to protect it from getting contaminated again.
- Adjust the mattress base to a flat home position at its lowest level.
- Lock the electric adjustment functions to prevent them from being activated accidentally or by unauthorised persons.
- If the optional rechargeable battery is fitted: Charge the integrated rechargeable battery by connecting the bed to the mains electricity supply for about 8 hours, and then unplug the switch mode power supply from the socket and hang it on the headboard with the fixing clip.

Repeat this procedure every 3 months to maintain the battery capacity

- Engage the brakes on the bed.

10 Dismantling the Care Bed

- Move the backrest, thigh rest and lower leg rest to a horizontal position.
- Move the mattress base to the highest position.
- Disconnect the switch mode power supply plug from the mains socket.
- Remove the safety sides. **Caution: Do not let them drop!**
- Dismantle the side panel.
- Dismantle the headboard and footboard.
- Remove the fixing bolts for the backrest motor and place the backrest motor on the floor.
- Remove the fixing bolts for the thigh rest motor and place the thigh rest motor on the floor.
- Undo the connection screws on the mattress base at the head and foot end.
- Take the mattress base off.
- Reinsert the plug of the switch mode power supply into the mains socket.
- Move the chassis to the lowest position.
- Disconnect the switch mode power supply plug from the mains socket.
- Insert the backrest motor and thigh rest motor in their transport position and secure these with bolts.
- All loosened screws should be re-tightened for transport, and the plug cover should be put back in position (to prevent it from getting lost).

11 Disposal

11.1 Disposal of the Bed

If the bed is to be disposed of, the plastic and metal parts must be separated and disposed of properly in accordance with relevant local and national environmental regulations and legislation of the town or country concerned. If you have any queries, you can contact your local municipal waste company or our service department.

11.2 Disposal of Packaging

Packaging must be sorted according to recyclable and other types of waste and recycled and disposed of in line with the environmental regulations and legislation of the country concerned. Recycling and disposal are governed in the European Union by the EU Waste Framework Directive 2008/98/EC.

11.3 Disposal of Electrical Components

This bed – since it is electrically adjustable – is classified as (type b2b) industrial electrical equipment in accordance with the WEEE Directive 2012/19/EC (implemented in Germany in the law governing electrical equipment).

The electrical components used are free from prohibited hazardous substances in compliance with the RoHS-II Directive 2011/65/EU.

Replaced electrical components (drives, control units, handsets, etc.) must be treated as electric scrap in accordance with the WEEE Directive 2012/19/EU and disposed of accordingly.

The operator of this bed is legally obliged to return the electrical components directly to the manufacturer and not to dispose of them at municipal waste collection points. Burmeier and its service and sales partners will take these components back. The return of these components is covered by our General Terms and Conditions.

12 Appendix

12.1 Accessories

The bed must only be operated with original Burmeier accessories. Burmeier does not accept any responsibility for accidents, defects and hazards that arise from the use of other accessories.

WARNING

Risk of injury

Failure to heed this warning may result in physical injury to residents

- Make sure that using safety sides, infusion stands, etc. do not produce any crush or shearing zone for the resident when the back or leg rest is adjusted
- If this cannot be guaranteed, care staff must safely prevent the resident from adjusting the back and leg rests.
- Lock the handset adjustment options in such cases.

Up-to-date lists of accessories can be obtained from Burmeier and their sales partners. Please quote the bed model.

Here are some examples of accessories:

- Mattresses, various, dimensions → see [Part B: Mattress requirements](#) » 67
- Reading lamps, various
- Protective covers for safety sides
- Under bed light
- Wall deflector rollers
- Linen holder

Removable parts: Plug-in power supply: Manufacturer: Linak; type SMPS 20

12.1.1 Mattress requirements

Basic dimensions:

Length x width	200 x 90 cm
Thickness/height	10-19 cm (metal mattress base) 10-15 cm (comfort mattress base)
Foam rubber density	min. 38 kg/m ³
Compression hardness	min. 4.2 kPa
Applicable standards:	DIN 13014
	DIN 597 Part 1 and 2

12.1.2 Safety Side Requirements

Height above mattress	≥ 220 mm
Gap between bars and mattress base	≤ 120 mm
Foam rubber density	min. 40 kg/m ³
Gap between safety side and headboard	≤ 60 mm
Gap between safety side and footboard	≥ 318 mm

Permissible accessory safety sides:

Type/model	Split safety side (TSG)	Full-length safety sides (DSG)
Item no.: (right-hand side)		
Item no.: (left-hand side)		

12.2 Translation of EC Declaration of Conformity

We, Burmeier GmbH & Co. KG, in our sole responsibility as the manufacturer, hereby declare that this product complies with the provisions of REGULATION (EU) 2017/745 OF THE EUROPEAN PARLIAMENT AND THE COUNCIL of 5 April 2017 (MDR).

The full latest version of the declaration of conformity is available on request from our customer centre (for contact details please refer to the chapter [Part A: Address, Market Information](#) » [1](#)) or go to the dealer area on our website.

Part C: Care staff and residents

Regia (Standard) care bed

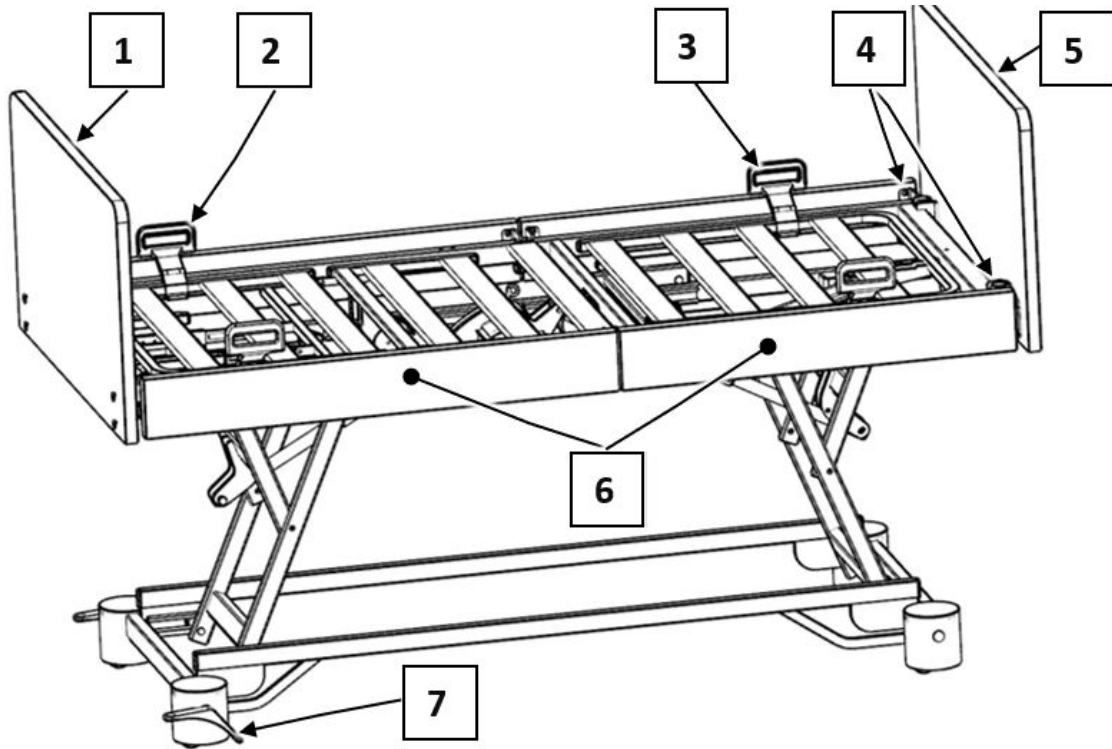

Regia care bed DSG (optional)

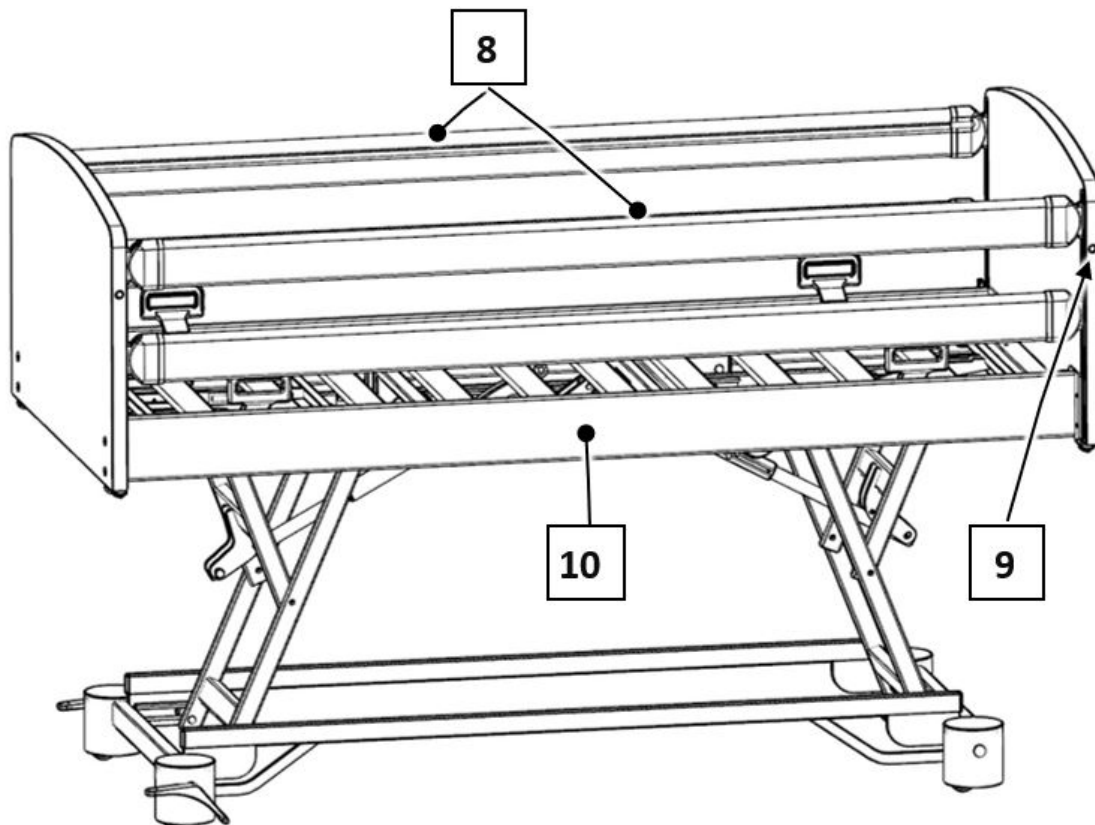

Regia care bed with telescopic safety sides (TSG) (optional equipment)

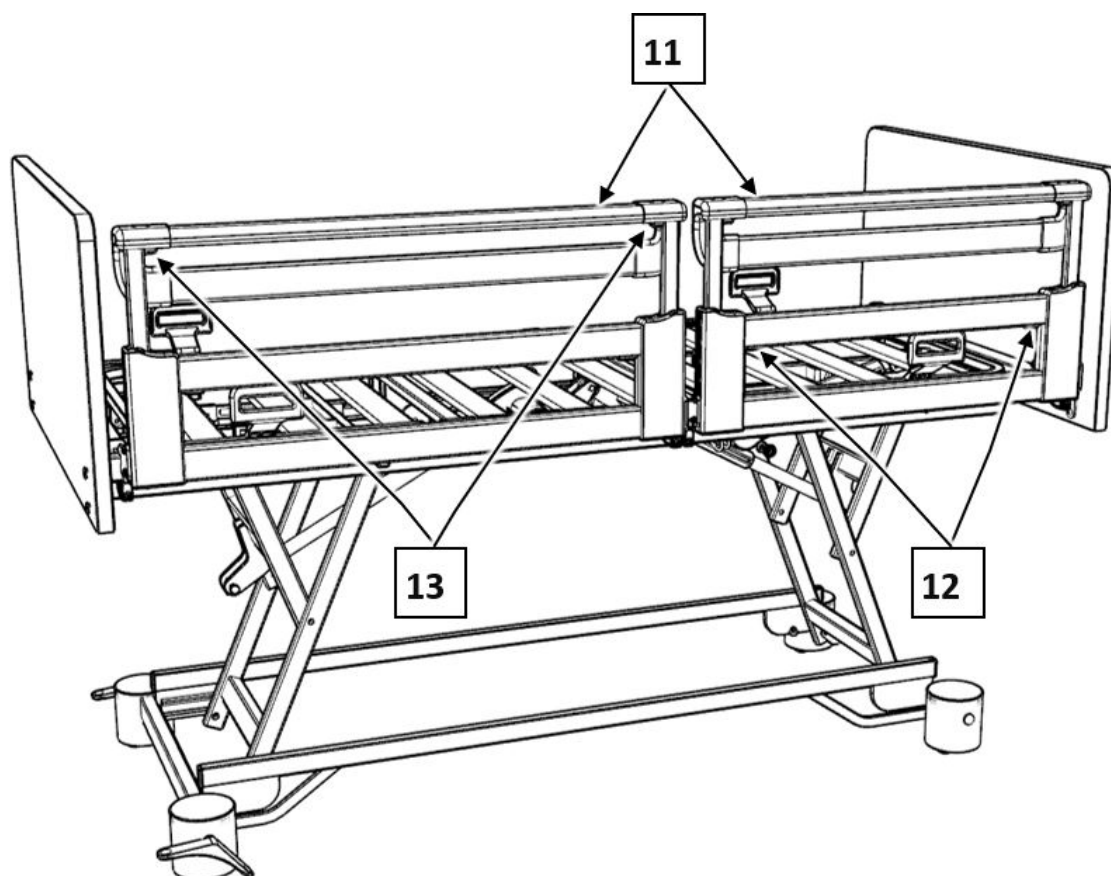

[1] Footboard	[2] Lower leg rest handle (both sides) / mattress retainer bar
[3] Backrest handle (both sides) / mattress retainer bar	[4] Adapter sleeves for patient lifting pole (head end) 2x
[5] Headboard	[6] Side panels (both sides) 4x
[7] Brake lever for operating castor brakes, foot end (both sides)	[8] "Easy Click" full-length safety side (DSG) bars (4x)
[9] Full-length safety side release button (4x)	[10] Side panel (one-piece), only possible in conjunction with full-length safety sides (DSG) (2x).
[11] "Easy Switch" split safety side (TSG) (both sides, telescopic)	[12] Release buttons for lower bar
[13] Release buttons for upper bar	

Contents

Part C: Care staff and residents

1	Target Groups, Qualifications and Duties.....	1
1.1	Care staff.....	1
1.1.1	Duties of Care Staff.....	1
1.2	Residents.....	2
2	Safety Information.....	3
2.1	Safety Information for Operating the Bed.....	3
2.1.1	Electrical cables and connections.....	3
2.1.2	Operating time of electric drives.....	4
2.1.3	Handset.....	4
2.1.4	Bed adjustment.....	5
2.2	Safety Information for Attachments and Additional Equipment.....	6
2.2.1	Use of Resident Lifts.....	6
2.3	Safety information for accessories.....	7
2.4	Safety information for users and residents.....	7
3	Operation.....	8
3.1	Handset.....	8
3.1.1	Operation.....	8
3.1.2	Special functions.....	10
3.1.3	Saving a new “intermediate stop” position.....	11
3.1.4	Resetting the “intermediate stop” position to the factory default setting.....	11
3.2	Trendelenburg handset (optional equipment).....	11
3.3	Locking Functions.....	13
3.3.1	Standard handset locking functions.....	14
3.3.2	Trendelenburg handset locking functions.....	14
3.4	Under bed light (optional equipment).....	15
3.5	Mains cable holder.....	15
3.6	Castors.....	16
3.7	Patient lifting pole.....	17

3.7.1	To Insert/Remove.....	18
3.7.2	Slewing Range.....	19
3.8	Triangular grab handle.....	19
3.8.1	Service Life.....	19
3.8.2	Adjusting the Grab Handle.....	20
3.9	Safety sides.....	20
3.9.1	Split safety side (TSG) (optional equipment).....	22
3.9.2	Full-length safety sides (DSG).....	25
3.10	Lower leg rest.....	27
3.10.1	Raising by Hand.....	27
3.10.2	Lowering by hand.....	28
3.10.3	Lowering using the handset.....	28
3.10.4	Raising using the handset.....	28
3.11	Emergency release of the backrest.....	29
4	Troubleshooting.....	31
5	Maintenance.....	35
6	Cleaning and Disinfection.....	38
6.1	Cleaning - Private Use.....	38
6.2	Cleaning agents and disinfectants.....	38

1 Target Groups, Qualifications and Duties

1.1 Care staff

Care staff are persons who, based on their training, experience or briefing, are qualified to operate the care bed on their own authority or to carry out work with the care bed, or have been instructed how to handle the care bed. Furthermore, they are able to recognise and avoid potential hazards and assess the clinical condition of the resident.

1.1.1 Duties of Care Staff

- Ensure that the operator instructs you in the safe operation of this care bed.
- Ask a healthcare professional for advice if you are uncertain about a possible application of safety sides or about the necessity of activating the locking functions of the electrical adjustments.
- In Germany: Before using a care bed, you, as care staff, must check each time that the care bed is fully functional and in perfect working order, and must observe the instructions in the instruction manual - particularly the safety information - during operation and maintenance in accordance with § 2 of the Medical Devices Operator Ordinance (MPBetreibV).
Only by doing so can operating errors be prevented and correct handling ensured in order to prevent injuries and damage from occurring.
- In other countries the relevant national regulations concerning the duties of care staff must be followed! Please also follow the corresponding instructions in the instruction manual for accessories attached to the bed.
- Pay special attention here to the safe routing of all loose connector cables, tubing, etc. Ensure that no obstacles, such as bedside cabinets, supply rails or chairs could impede adjustments to the bed.
- If any additional devices (such as compressors for positioning systems) are attached, ensure that these are securely fastened and are working properly.
- If anything is unclear, please contact the manufacturer of the device, or Burmeier.

CAUTION

Risk of injury

Failure to heed this warning may result in injuries as well as material damage due to damage to the bed and resulting malfunctions.

- If any damage or malfunction is suspected, take the bed out of service.
- Unplug the bed from the mains supply immediately.
- Indicate clearly that the bed is "OUT OF ORDER".
- Report this immediately to the operator responsible.

⇒ A checklist for assessing the proper condition of the bed is given in the chapter [Part C: Maintenance](#) » [35](#).

1.2 Residents

In this instruction manual, the term resident is defined as a person who is infirm or in need of care and occupies this care bed.

It is a requirement that the operator or care staff instructs each new resident in the bed functions that are important for him/her.

2 Safety Information

2.1 Safety Information for Operating the Bed

2.1.1 Electrical cables and connections

WARNING

Risk of injury

Failure to heed this warning may result in fatal injuries due to damaged mains power cables.

- Do not use damaged mains power cables! This can lead to electric shock, fire and other hazards as well as malfunctions.
- Replace damaged mains power cables immediately!
- Route the mains cable in such a way that it cannot be pulled, driven over or damaged by moving parts, or in any other way, when the bed is operated. Before moving the bed, always make sure that you have unplugged it from the mains supply.
- Before moving the bed, always make sure that you have unplugged it from the mains socket.
- Hang the mains cable in the mains cable holder provided on the headboard to ensure that it will not fall off or trail on the floor.
- At weekly intervals when the bed is being used, carry out a visual inspection of the mains cable to check for damage (scuffing, exposed wires, kinks, pressure points, etc.). A check should also be performed whenever the cable has been subjected to any mechanical load, e.g. has been driven over by the bed itself or by an equipment trolley, or whenever the cable has been bent, stretched or violently pulled, e.g. due to the bed rolling away while it is still plugged into the mains socket, and before plugging the cable back into the mains socket whenever the bed has been moved or relocated.

- Check the strain relief of the power mains cable regularly to ensure that it is securely fixed.
 - Do not place multiple socket outlets under the bed. This could cause electrical hazards due to damaged mains cables or penetrating fluids.
 - Do not continue to use the bed if you suspect that the mains cable could be damaged.
-

2.1.2 Operating time of electric drives

-  Continuous operation must not exceed two minutes! After this time, a rest period of at least 18 minutes must be observed. If the electric drive is operated for a much longer period, e.g. due to the resident continually "playing" with the handset, the thermal protection device integrated in the control unit will deactivate power supply for safety reasons. Depending on the extent of overloading, it may take a few minutes until you can carry out any further adjustments. Also read and note the additional information contained in the chapter [Part C: Troubleshooting](#) » 31.

2.1.3 Handset

When the handset is not in use, position it on the bed using its elastic hook so that it cannot fall off accidentally or be otherwise damaged.

When routing the handset cable, ensure that it cannot be damaged by any moving parts of the bed:

- Hang the handset up with the keypad facing inwards towards the bed in order to prevent adjustments from being made accidentally.
- Make sure that the cable cannot be crushed, stretched or otherwise damaged by moving parts of the bed.

This will prevent unnecessary hazards arising through automatically activated electrical adjustments that were not previously locked-out and system faults occurring due to locked electrical adjustment systems.

To safeguard the resident, and children in particular, against unintentional electrical adjustments, place the handset out of their reach (e.g. at the foot end of the bed) or lock the appropriate adjustment options.

In these cases, adjustments must only be performed by a person trained by the operator, or in the presence of a trained person!

CAUTION

Risk of injury

Failure to heed this warning may result in physical injury due to unintentional incorrect operation.

Lock the operating functions for the resident on the handset if:

- The resident is unable to operate the bed safely or to free himself/herself from potentially dangerous situations,
- the resident is exposed to an increased risk of entrapment during backrest and thigh rest adjustments when the safety sides are raised,
- The resident could be at risk due to unintentional motorised adjustments,
- Children are left unsupervised in the room with the care bed.

2.1.4 Bed adjustment

CAUTION

Risk of injury

Failure to heed this warning may result in physical injury due to entrapment or crushing!

- When making any adjustments, always ensure that no limbs belonging to the resident, care staff or other persons, especially playing children, could become trapped underneath the mattress sections or the mattress base during the adjustment.
- This bed is only intended for use as a single bed. Keep a minimum safety distance of one bedside cabinet width (approximately 60 cm) between one bed and the next.

ATTENTION

Material damage

Failure to heed this warning may result in the care bed being damaged, which could have an adverse effect on the loading capacity of the care bed or the adjusting functions.

Ensure that

- No obstacles such as bedside cabinets, supply rails, other equipment, chairs or wall protection rails are in the way,
- There are no objects lying on the chassis,
- People should not sit on slightly raised sections of the backrest, thigh rests and leg rests.

2.2 Safety Information for Attachments and Additional Equipment

2.2.1 Use of Resident Lifts

CAUTION

Risk of injury

Failure to heed this warning may result in material damage and injuries.

- Make sure that the attachment of accessories does not produce any crush or shearing zones for the resident when the bed sections are adjusted. If this cannot be ensured, you must lock those particular adjustment controls! (Use the locking functions on the handset for this purpose).

ATTENTION

Material damage

Failure to heed this warning may result in incorrect use or use of unsuitable accessories.

- When using external electrical components such as resident lifts, reading lamps, or compressors for positioning systems, ensure that their power cables will not become entangled or damaged by moving parts of the bed.
- Efficient and safe operation combined with maximum protection of residents can only be guaranteed if original Burmeier accessories designed for the relevant model of bed are used.

2.3 Safety information for accessories

CAUTION

Risk of injury

Failure to heed this warning may result in damage to property and injury due to the use of incorrect accessories.

- Efficient and safe operation combined with maximum protection of residents can only be guaranteed if original Burmeier accessories designed for the relevant model of bed are used!

2.4 Safety information for users and residents

Ensure that the operator/your medical supply store instructs you in the safe operation of this bed.

Ask a healthcare professional for advice if you are uncertain about a possible application of safety sides or about the necessity of activating the locking functions of the electrical adjustments.



3 Operation

3.1 Handset

3.1.1 Operation

The bed's electrical adjustment mechanisms can be controlled with the handset. The adjustment range for all functions is electrically/mechanically limited to the permitted ranges. For safety reasons, the handset features a number of locking functions. Adjustments can be locked on the handset in order to protect residents whose clinical condition is deemed by the doctor treating them to necessitate this.



- The handset can be hung at any position on the bed with its elastic hook.
- The spiral cable allows maximum freedom of movement.
- The handset is water-protected and can be wiped clean with a damp cloth.
- Explain the handset functions to the resident!
- The electric motors operate as long as the corresponding button is pressed.

- The buttons are usually used as such:  to raise and  to lower

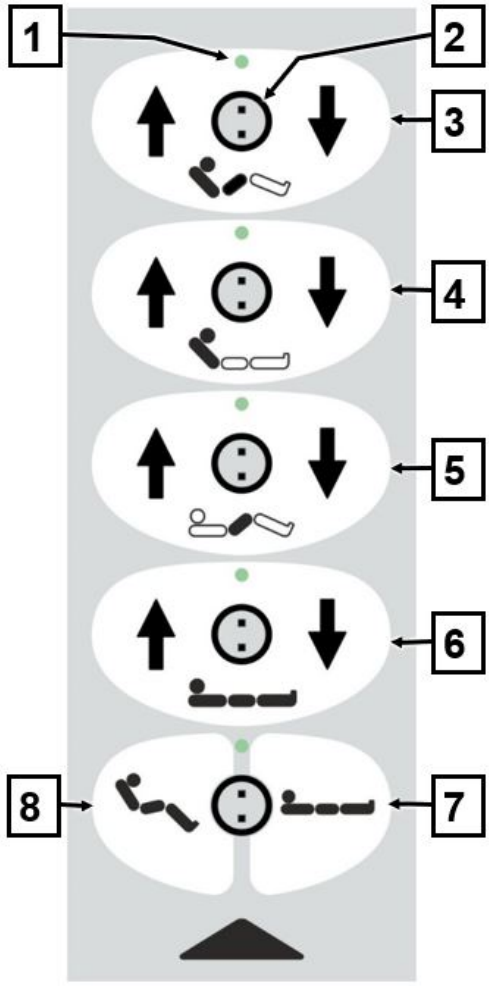
 Only one button can be pressed at a time, otherwise all adjustments stop (emergency off safety function).

	[1]	Indicator
	[2]	Lock
	[3]	Auto contour
	[4]	Backrest
	[5]	Thigh rest
	[6]	Mattress base height
	[7]	Sleep position
	[8]	Sitting position

	<p>Auto contour</p> <p>Raise: The backrest and thigh rest are raised at the same time.</p> <p>Lower: The thigh rest follows the backrest after a five second delay.</p> <p>This prevents the resident from sliding towards the foot end of the bed.</p>
	<p>Backrest</p> <p>The backrest can be raised to approx. 66°. Please also refer to the chapter Part C: Emergency release of the backrest » 29.</p>
	<p>Thigh rest</p> <p>The thigh rest can be raised to approx. 40°.</p>

	<p>Height adjustment</p> <p>Depending upon the bed model, the mattress base height can be adjusted from approximately 25 to 80 cm.</p> <p>During the height adjustment, continuous monitoring of the horizontal position occurs – including when a strongly imbalanced load is acting on the mattress base.</p> <p>An “intermediate stop” is made when lowering at approx. 38 cm. This makes getting into/out of bed easier. This height can be individually programmed for each resident (see chapter Part C: Saving a new “intermediate stop” position » 11). If the mattress base is tilted, it automatically moves into a horizontal position when it reaches the highest or lowest setting.</p>
	<p>Sitting position</p> <p>Initially, the backrest and thigh rest are raised (to an auto contour position). The mattress base is then tilted to a reverse-Trendelenburg position.</p>
	<p>Sleep position</p> <p>If this button is kept pressed, the mattress base is adjusted to the following positions in turn in the following order:</p> <ol style="list-style-type: none"> 1. to a horizontal position 2. the backrest is lowered immediately – the thigh rest follows after a delay of 9 seconds 3. To the “intermediate stop” position (pre-set to approx. 38 cm).

3.1.2 Special functions

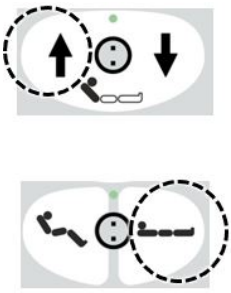
	<p>Special functions Switch the under bed light on/off (optional)</p> <p>Standard setting: The LED under bed light is active when connected to the mains power supply.</p> <p>Press the two buttons “Backrest UP” and “Backrest DOWN” at the same time for about 3 seconds to manually switch the under bed light on or off.</p> <p>For further details, see chapter Part C: Under bed light (optional equipment) » 15.</p>
---	--

3.1.3 Saving a new “intermediate stop” position

i This can only be saved if the mattress base is in a horizontal position.

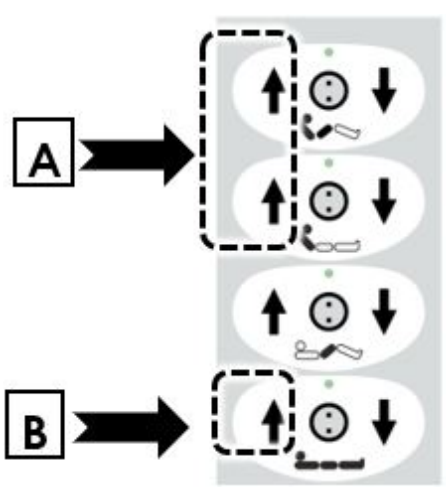

- Adjust the mattress base to the desired minimum height.
- Press both [A] buttons at once on the handset briefly three times.
- Then immediately press button [B].

As soon as the new position has been saved, a short signal tone sounds to confirm the change.

3.1.4 Resetting the “intermediate stop” position to the factory default setting

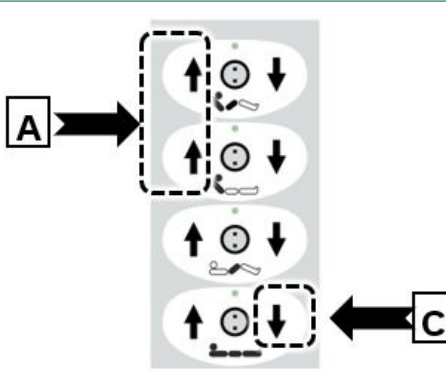

- Press both [A] buttons at once on the handset briefly three times.
- Then press button [C] immediately and hold for approximately 5 seconds until the pulsating signal tone stops.

3.2 Trendelenburg handset (optional equipment)

Tilting the mattress base can help to bring the resident into a suitable position to allow the user to provide care.

⚠ WARNING

Risk of injury

Failure to heed this warning may result in physical injury due to incorrect use of the handset.

- Only users are authorised to use this handset. Lock the handset's functions if they are not being used!
- Setting the bed to a Trendelenburg position may pose a hazard for the resident.

i Only one button can be pressed at a time, otherwise all adjustments stop (emergency off safety function).

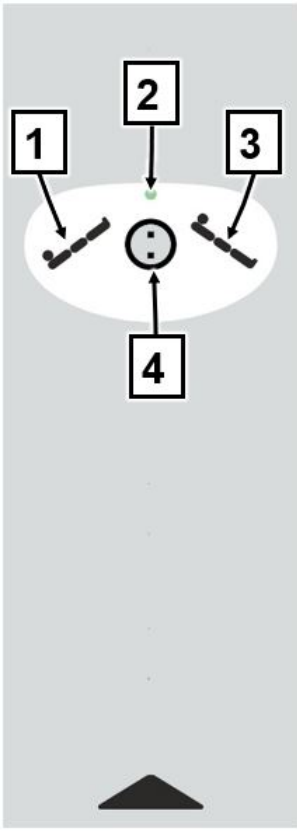
[1]	<p>Trendelenburg position Pressing this button will move the mattress base into the Trendelenburg position. If the bed is in a Trendelenburg position, this function will automatically cause the mattress base to move into a horizontal position when it is moved into its lowest or highest position.</p>	
[2]	<p>Indicator</p>	
[3]	<p>Reverse-Trendelenburg position</p> <p>Pressing this button will move the mattress base into the reverse-Trendelenburg position. If the bed is in a reverse-Trendelenburg position, this function will automatically cause the mattress base to move into a horizontal position when it is moved into its lowest or highest position.</p>	
[4]	<p>Lock</p>	

3.3 Locking Functions

WARNING

Risk of injury

Failure to heed this warning may result in physical injury due to incorrect use of the handset.

- Only care staff are authorised to use the locking function!
- If the clinical state of the resident is so critical that any adjustment using the handset places him/her at risk, then carers must lock this adjustment function immediately. The care bed remains in the position it was in at the time it was switched off.

ATTENTION

Material damage

Failure to heed this warning may result in damage to the handset.

- Do not forcibly turn the locking key beyond the limit stop of the lock! The lock or the entire handset can be damaged.



WARNING

Risk of injury

Failure to heed this warning may result in physical injury due to incorrect use of the handset.



- The bed is delivered with a locking key, which is attached to the handset with a cable tie.
- The locking key is not intended to be used by the resident.
- The locking key must be removed from the handset
- Care staff or a person authorised by the doctor should take the locking key for safekeeping.

3.3.1 Standard handset locking functions

Tool/Symbol	Function/Explanation
	<p>Turn the respective lock on the handset clockwise to the locked position using the locking key.</p> <p>The colour of the respective display changes from green to yellow.</p>
	<p>Operation enabled:</p> <p>The lock is in a vertical position</p> <p>Colour of display: green</p> <p>Keys can be operated (“click” sound)</p>
	<p>Drive locked:</p> <p>Lock turned approx. 15° clockwise</p> <p>Colour of display: yellow</p> <p>Keys are locked</p>

3.3.2 Trendelenburg handset locking functions

On the Trendelenburg handset, there is a choice of 2 levels that can be set with the locking key:

Symbol	Function/Explanation
	<p>All adjustment options are locked</p>
	<p>All functions are activated</p>

3.4 Under bed light (optional equipment)

 Similar to illustration!



The energy-saving, long-lasting LED under bed light provides safe orientation during the night and can reduce the risk of falls. The light is sufficiently subtle, however, to not disturb the resident of the adjacent bed.

The light goes on automatically if the bed is connected to the mains power supply.

Press the two buttons “Backrest UP” and “Backrest DOWN” at the same time for about 3 seconds to manually switch the under bed light on or off.



 If the bed is also equipped with the “Out-of-Bed system” *, the under bed light can be automatically switched on/off with this system; see separate “e-help (Out-of-Bed)” manual.

3.5 Mains cable holder

The cable for the switch mode power supply is fitted with a mains cable holder. The holder is located on the mains cable itself.

CAUTION

Risk of injury

Failure to heed this warning may result in physical injury due to electrical hazard, as well as material damage.

- Hook the mains cable holder onto the headboard before moving the bed to prevent the mains cable from being driven over, crushed or torn off.
- Such damage could lead to electrical hazards and malfunctions.

3.6 Castors

The bed is equipped with four lockable castors which can be centrally braked at the foot end of the bed. The bed can be moved within the room even with a resident in it (if the mattress base is in its lowest position).

WARNING

Risk of injury

Failure to heed this warning may result in injuries due to falling after the bed rolls away when getting into/out of bed, as well as to crushing.

- To avoid toe injuries, wear closed shoes when operating the bed.
- Ensure that the brakes of the bed are always adequately applied (at least three castors) when a resident is left unattended.
- If the bed is standing on a sloping floor (e.g. on a ramp), then the brakes must be applied on all castors.
- A safe and secure bed position must always be ensured.

ATTENTION

Material damage

Failure to heed this warning may result in damage to the bed and to its surroundings.

- Only move the bed around if the mattress base is adjusted to its lowest position.
- Before moving the bed, always ensure that the switch mode power supply is placed safely on the bed to prevent it from falling off.

- Before moving the bed around, always ensure that the castor brakes have been released. This prevents excessive wear of the castor treads and scuffing marks on the floor.
- Make sure that the cable of the switch mode power supply cannot be stretched, rolled over or otherwise damaged when moving the bed.
- Check that all cables, tubes or leads belonging to any accessory devices that are attached to the bed are safely secured and cannot be damaged.

- i** A bed that is occupied by someone should be moved around only inside the room. Always avoid moving the bed over long distances along corridors and across thresholds.
- i** The bed must be raised to activate the brake. The mattress base must not be in the lowest position, however.

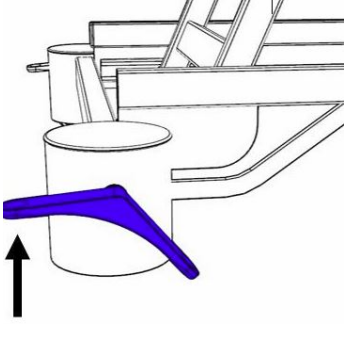
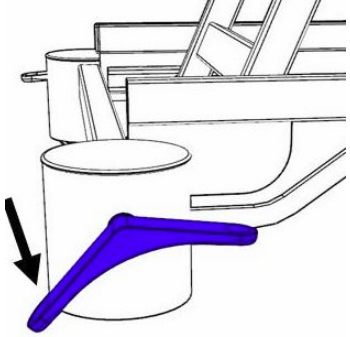
Brake	Move
Lift the brake pedal with your foot.	Press the brake pedal down with your foot.
	

3.7 Patient lifting pole

WARNING

Risk of injury

Failure to heed this warning may result in injury and damage to property due to excessive loading of the patient lifting pole.

- The maximum loading capacity at the front end of the patient lifting pole is 75 kg.

- The loading capacity is rated to allow a heavy patient lying in the bed to sit up by themselves using their own strength.
- Do not use the patient lifting pole as a lifting mechanism for the patient.
- Do not allow a heavy patient to “hang” with his/her entire weight on the patient lifting pole (e.g. when getting out of bed).

A patient lifting pole **[D]** attached to the bed makes it easier for the resident to get into/out of bed.

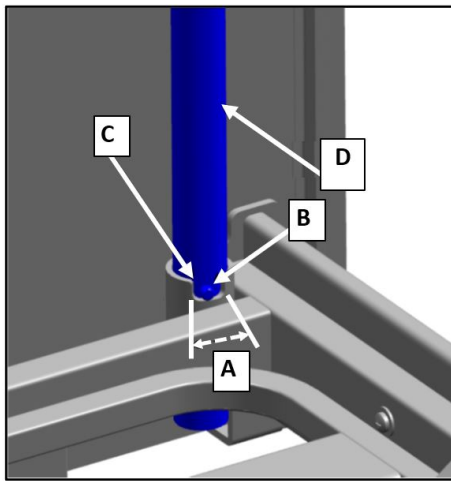

Part C: Image1:
Lifting Pole Adapter Sleeves

There are two lifting pole adapter sleeves at each corner of the head end of the mattress base. There is a notch **[A]** on the surface of the lifting pole adapter that, together with the pin **[B]**, restricts the slewing range **[C]** of the patient lifting pole. The lifting pole should be fitted to the side of the bed that the resident gets in and out of bed.

3.7.1 To Insert/Remove

To insert the pole

1. Insert the lifting pole in the sleeve. The metal pin **[B]** on the pole must be located in the notch **[A]** in the retainer sleeve.

Remove

2. Pull the lifting pole up and out of the sleeve.

3.7.2 Slewing Range

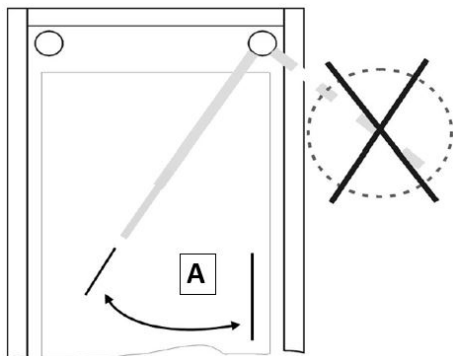

Part C: Image2:
Slewing range of patient lifting pole

WARNING

Risk of injury

Failure to heed this warning may result in injury and damage to property due to the bed tipping up.

- Only swivel the patient lifting pole within the slewing range of the bed [A].
- The metal pin of the patient lifting pole must therefore always sit in the adapter sleeve recess!

⇒ Otherwise, there is a danger that the bed will tip up when weight is applied to the pole.

3.8 Triangular grab handle

A triangular grab handle can be attached to the lifting pole. The resident can use this grab handle to sit up and readjust his/her position more easily. Check the grab handle and belt regularly for damage (see [Part C: Maintenance](#) » 35). Replace damaged grab handles or straps immediately.

3.8.1 Service Life

A date is printed on the grab handle. In normal use, the grab handle has a service life of at least five years. After this period, a visual and functional inspection must be carried out every six months to determine whether the handle may continue to be used.

3.8.2 Adjusting the Grab Handle

Due to its adjustable belt, the grab handle height can be adjusted to between about 55 cm and 70 cm (measured from the upper edge of the mattress).

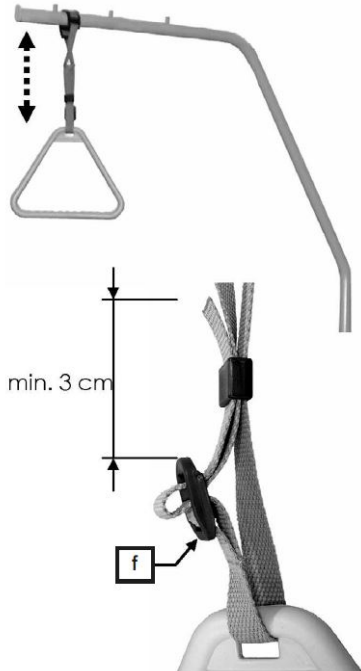

Part C: Image3:
Adjusting the Lifting Pole

- Slide the fixed loop of the grab handle over the first bolt on the lifting pole.
- Check the secure position of the grab handle by tugging hard on it.

i The maximum loading capacity at the front end of the lifting pole is 75 kg.

- The height of the triangular grab handle can be adjusted using the strap.
- Make sure that the strap is correctly threaded through the buckle.
- Make sure that the end of the strap projects at least 3 cm from the buckle **[f]**.

3.9 Safety sides

Safety sides provide suitable protection for residents against falling out of bed. They are not intended as a device to prevent the resident from intentionally leaving the bed.

If not used properly, there is a considerable danger of strangulation for the resident! Be sure to observe the following safety information:

 **WARNING****Risk of injury**

Failure to heed this warning may result in physical injury due to the incorrect use of safety sides!

- Only use technically perfect, undamaged safety sides which engage securely!
- Use only the safety sides described in this manual. Safety sides are either factory integrated into the bed or available as accessories.
- Before using the safety sides, assess and take into consideration the clinical condition and particular physical build of the resident:
- *For example, if the resident is extremely confused or very restless, avoid using safety sides as far as possible and make use of alternative or additional safety measures such as restraint sheets, fall protection mats, setting the mattress base to the lowest position etc.*
- *For especially small, slim residents, additional protective measures for reducing the space between the bars on the safety sides may be necessary. In these cases, use protective covers (accessory), posey belts, etc. (This is the only way to ensure effective protection and reduce the risk of the patient getting trapped or slipping through the gaps).*
- To prevent putting residents at risk of entrapment or suffocation, only use suitable mattresses (not too soft) complying with DIN 13014, with a volume weight of at least 38 kg/m³ and dimensions complying with the specifications in the instruction manual.
- The maximum permissible mattress height depends on the model and position of the safety sides used. An effective safety side height of at least 22 cm above the non-occupied mattress must be ensured. If this dimension is not adhered to, you must take additional/alternative measures on your own responsibility and according to your assessment of the risks in view of the clinical condition of the resident, such as:
- *providing additional safety systems for the resident,*
- *arranging for the resident to be monitored regularly and more frequently,*
- *Issuing internal instructions for users*
- When the safety sides are raised, the electrical adjustment of the backrest and thigh rest must always be locked:

- *Attach the handset out of reach of the resident (e.g. at the foot end of the bed).*
- *Lock the handset adjustment options.*
- Otherwise there is a danger of limbs being crushed or trapped by the safety sides if the resident inadvertently activates the handset. The effectiveness of the safety sides can also be reduced if any mattress base sections are raised to a high level. Place the handset out of reach (e.g. at the foot end of the bed) or lock the handset adjustment options.

WARNING

Risk of injury

Failure to heed this warning may result in physical injury due to entrapment/suffocation. Please follow the following instruction if the bed is only equipped with side panels on one side and safety side(s) on the other side:

An inserted mattress can slip if the mattress retainers are not raised. The resident can get stuck in the resulting free space between the mattress base and the safety side.

- Only use mattresses with suitable dimensions, as described in the chapter entitled “Accessories”
- Always use the mattress retainers [1] that are fitted to the bed, since the side panel itself does not fix the mattress in place.

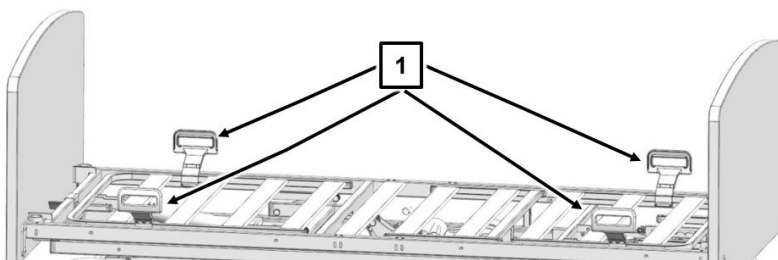

3.9.1 Split safety side (TSG) (optional equipment)

The “Easy Switch” split safety side can be easily raised or lowered and can be adjusted to various positions.

Requirements for operation: The split telescopic safety side (TSG) has been fitted to the bed at the fixing points provided for this purpose in accordance with the assembly instructions.

3.9.1.1 Raising

Grasp the top bar [1] with both hands and pull the safety side up as far as it will go.
Repeat this procedure with the middle bar [2].

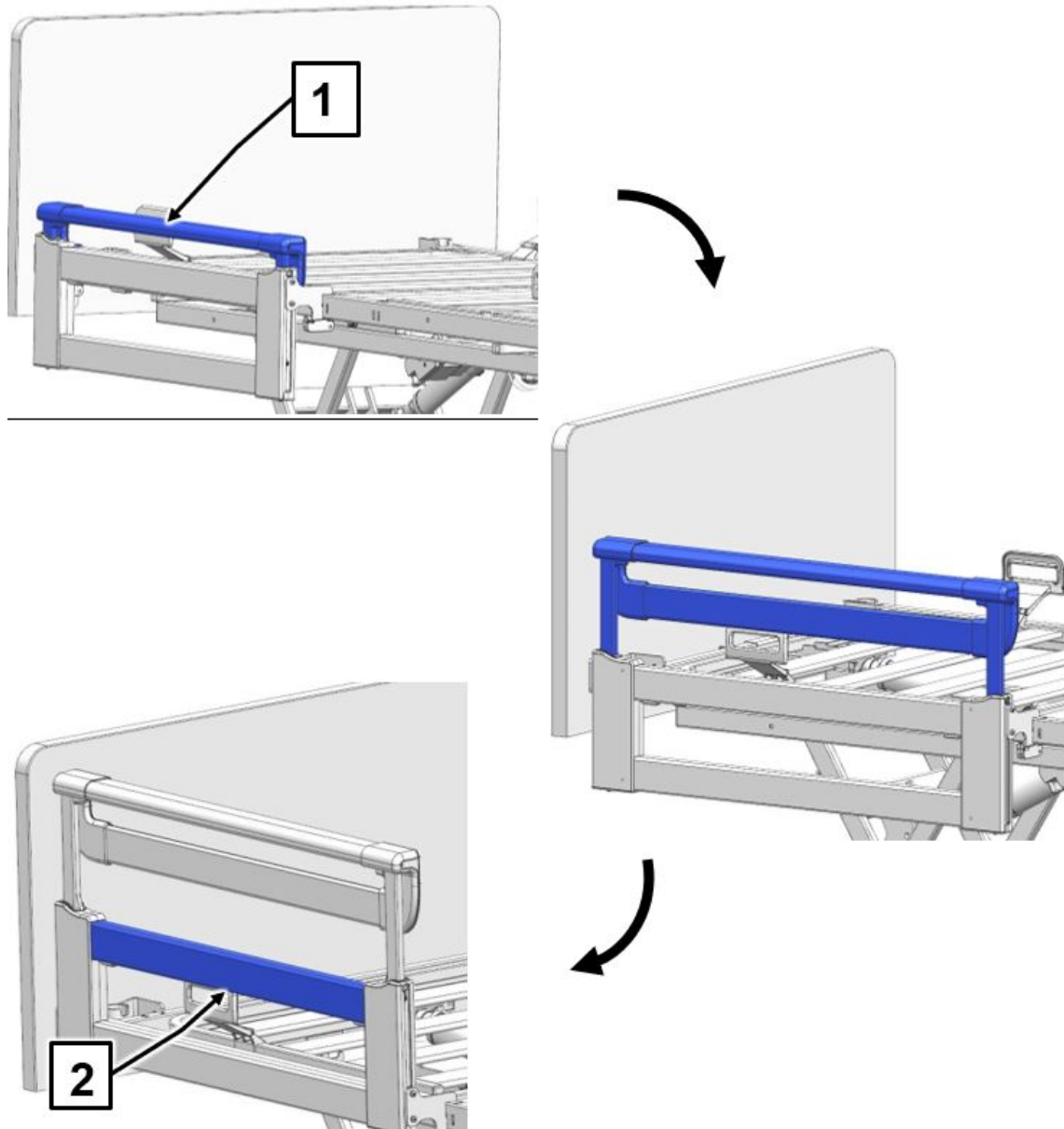

Various position options

The split safety sides can be positioned as follows:

Fully-lowered safety side	Top bar raised
---------------------------	----------------

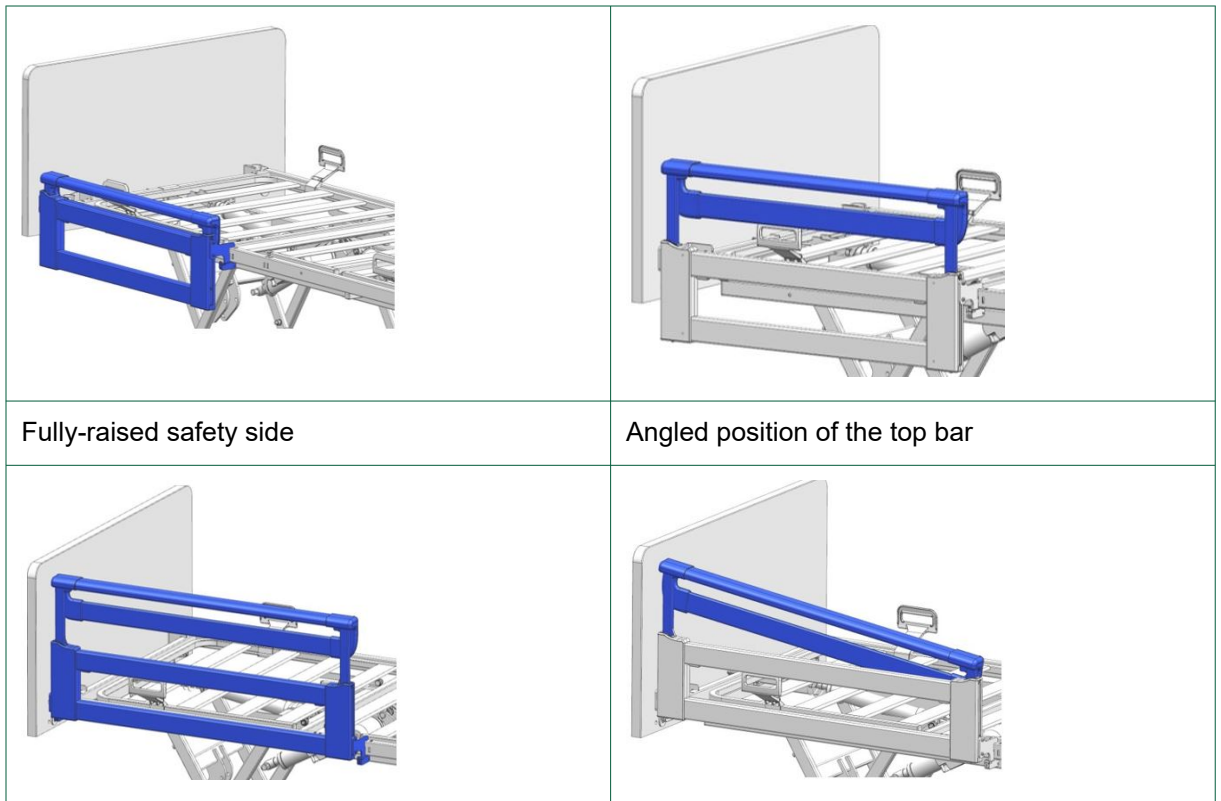

3.9.1.2 Lowering

The split safety sides can be lowered in two stages (telescopic)

 **CAUTION**

Risk of injury!

Failure to heed this warning may result in physical injury due to entrapment and crushing.

- Be careful with fingers when adjusting and lowering the safety side. These can be crushed between the bed frame and the safety side!

Proceed as follows:

- First relieve the load on the safety side by lifting it slightly.
- Then press both release buttons for the upper bar [1] and lower the safety side.
- Repeat this procedure for the middle bar (release buttons [2]).

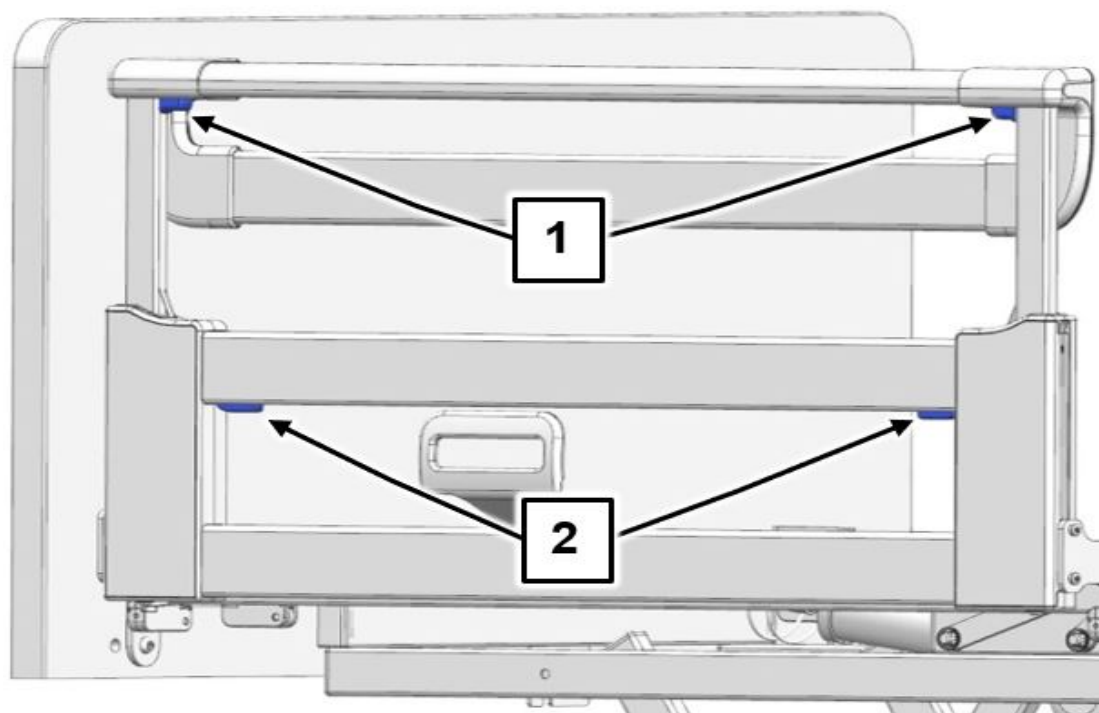

3.9.2 Full-length safety sides (DSG)

Requirements for operation: The full-length safety side (DSG) has been fitted to the bed at the fixing points provided for this purpose in accordance with the assembly instructions.

3.9.2.1 Raising

CAUTION

Risk of injury

Failure to heed this warning may result in physical injury due to the incorrect use of safety sides!

- When making any adjustments with the safety sides and backrest raised, always ensure that no limbs of residents, care staff or other persons, especially playing children, could become trapped and injured underneath the rests and mattress sections or between the mattress retainer and the safety sides during the adjustment.

1. Raise the safety side bars, one after the other, at one end until they click into place at both ends. It should not be possible to push the bars up or down.
2. Check that the safety side bars are securely locked in place by pressing down on them.

3.9.2.2 Lowering

1. Lift the safety side bars slightly at one end.
2. Press the release button [1] in with your finger.

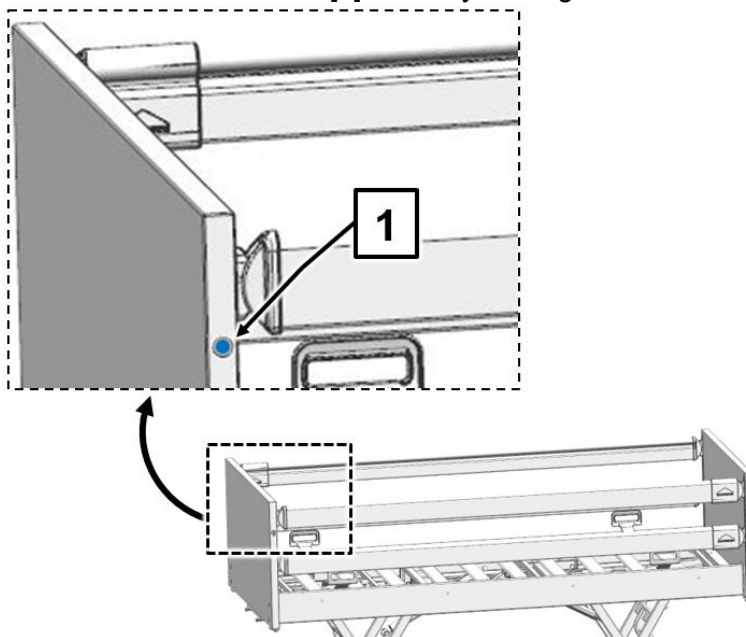

3. Lower the safety side bars slowly.

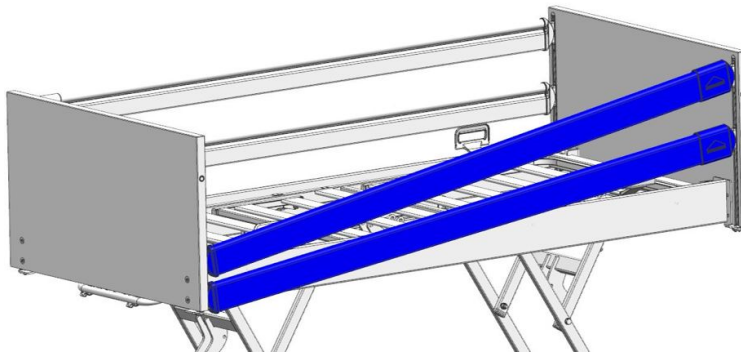

4. Repeat steps 2 and 3 at the other end of the bar.

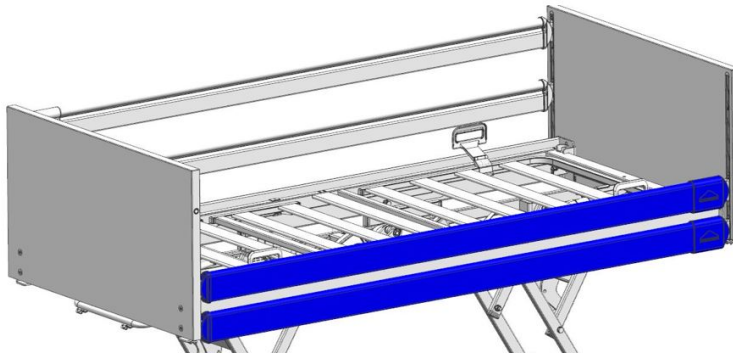

3.10 Lower leg rest

When the thigh rest is raised, the lower leg rest can be set individually. For this purpose, an adjustable fitting that locks the lower leg rest in position is located under the lower leg rest.

3.10.1 Raising by Hand

The thigh rest must be raised in order to raise the lower leg rest.

1. Raise the lower leg rest at the foot end - not using the mattress retainer bars - until the desired position is reached. The lower leg rest engages automatically.

3.10.2 Lowering by hand

WARNING

Risk of injury

Failure to heed this warning may result in physical injury due to entrapment or crushing of the member of staff.

1. Lower the lower leg rest carefully. There is a risk of injury occurring if the lower leg rest falls unchecked.

-
1. Raise the lower leg rest to its full extent.
 2. Then lower the lower leg rest slowly.

 If the thigh rest is lowered using the handset, the lower leg rest is automatically lowered as well.

3.10.3 Lowering using the handset

If the thigh rest is lowered using the handset, the lower leg rest is automatically lowered as well.

3.10.4 Raising using the handset

If the raised thigh rest is lowered using the handset, the lower leg rest locks into place in several intermediate positions. When the thigh rest is raised, the lower leg rest remains in position.

3.11 Emergency release of the backrest

WARNING

Risk of injury

Failure to heed this safety information and instruction manual may cause the backrest to fall unchecked, which could lead to serious injuries for both the member of staff and the resident.

- The CPR release may only be carried out in the case of extreme emergencies and by users who have a complete command of the procedure described below. We strongly advise you to practise CPR release of the backrest several times under normal conditions. In the event of an emergency, you will then be able to react quickly and correctly.
- If the backrest falls unchecked, the resident and/or the second member of staff could be injured!

In the event of power supply outages or electrical drive system failures, the raised backrest can be lowered by hand. **Two carers are absolutely necessary to carry this out!**

1. Release the load on the backrest [1] before carrying out the CPR release procedure.
2. To do so, the first person raises the backrest [1] slightly by gripping the outside frame [2] of the head section and holds the backrest in this position.
3. The second person now removes the locking pin [3]. To do so, swivel the curved clip [4] away and draw the bolt and pin, together with the clip, out of the backrest motor lifting pipe.

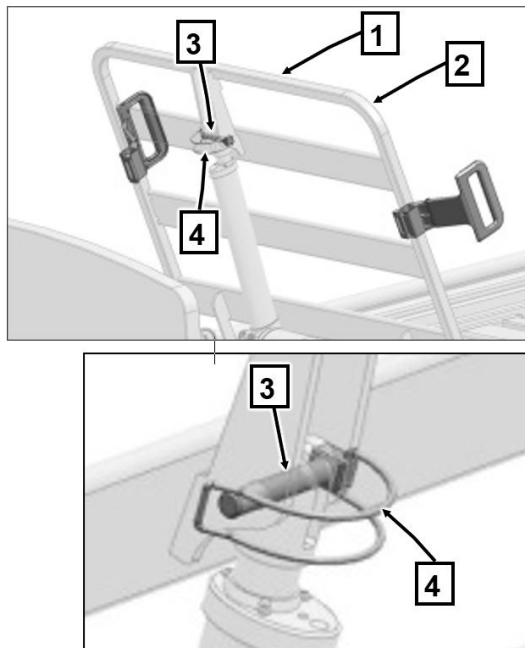

4. The motor is now separated from the backrest and will fall off.
5. The first carer then carefully lowers the backrest. **Attention:** Hold the backrest firmly when lowering it, as it could otherwise fall uncontrollably!

To return the bed to its original state:

1. Swing the lifting pipe up again, use the pin to secure it in place in the motor connector mount and fold the curved clip back over.
2. Insert the pin again from the side of the thigh rest motor.

4 Troubleshooting

The following table is a guide to rectifying faults: If malfunctions occur while the bed is in use, and care staff are unable to remedy them with the aid of the troubleshooting table, the maintenance and repair personnel of the bed operator concerned must be informed.

WARNING

Risk of injury

Failure to heed this warning may result in physical injury due to electric shock.

- On no account should care staff attempt to rectify malfunctions involving electrical components!

WARNING

Risk of injury

Failure to heed this warning may result in life-threatening injuries due to electric shock.

- Any work and/or repairs to the electrical drive system may only be carried out by service engineers, the drive manufacturer or by qualified and authorised electricians in compliance with all the relevant VDE and safety regulations!

Problem	Possible causes	Solution
Handset/drive system not working (bed is connected to the mains power supply)	<ul style="list-style-type: none"> • Switch mode power supply not inserted • No power supply to mains socket • The switch mode power supply is not inserted properly • Drives are locked or defective • Handset, switch mode power supply cable or control unit cable defective 	<ul style="list-style-type: none"> → Plug in the switch mode power supply; the green LED must light up on the control unit → Check socket and fuse box → Check plug connections → Release functions (see Part C: Standard handset locking functions » 14) → Inform your operator if repairs are necessary

Problem	Possible causes	Solution
Green LED on external switch mode power supply* does not light up and drive system does not work	<ul style="list-style-type: none"> • The switch mode power supply is not inserted properly • No power supply to mains socket • Switch mode power supply faulty 	<ul style="list-style-type: none"> → Plug in the switch mode power supply → Check the mains socket and fuse box → Replace the switch mode power supply with a new one; inform your operator to arrange for the necessary repairs
<p>If an external switch mode power supply* is used:</p> <p>Drives stop suddenly after lengthy period of adjustment</p>	<ul style="list-style-type: none"> • Thermal switch in switch mode power supply was triggered by overload 	<ul style="list-style-type: none"> → Do not make continuous bed adjustments for more than 2 minutes! After continuous operation for two minutes, let the device rest for at least 18 minutes (see Part C: Operating time of electric drives » 4) → To reset the switch mode power supply after an overload: Disconnect the device from the power supply and let it cool down for at least 30 minutes. Then reconnect the device to the power supply. If the device still does not function: Device is faulty – replace the device
<p>LED on external switch mode power supply*:</p> <p>lights up green constantly; LED does not light up, yellow when buttons are pressed on the handset</p>	<ul style="list-style-type: none"> • Handset faulty • The cable from the switch mode power supply (24 volt) is not plugged in properly • Functions are locked on handset 	<ul style="list-style-type: none"> → Replace handset → Check plug connections → Release functions (see Part C: Standard handset locking functions » 14)
Handset not functioning, adjustments are not locked	<ul style="list-style-type: none"> • Handset faulty • The control unit has detected a fault and for safety reasons has locked the adjusting functions 	<ul style="list-style-type: none"> • Replace the handset with a new one • Perform RESET; see Part B: Control unit – Reset » 62; if it occurs again: have drive system checked. Inform your operator if repairs are necessary
Battery-powered operation not possible	<ul style="list-style-type: none"> • Battery discharged • Cable from battery not properly plugged in 	<ul style="list-style-type: none"> • Connect the bed to the mains supply for approx. 8 hours • Connect the battery cable correctly

Problem	Possible causes	Solution
Continuous alarm sounds during battery mode	<ul style="list-style-type: none"> Battery capacity depleted 	<ul style="list-style-type: none"> Connect bed to the mains supply to recharge the battery as soon as possible
Operation with sufficiently charged battery only possible for a short time	<ul style="list-style-type: none"> Limit of battery's service life reached 	<ul style="list-style-type: none"> Replace the battery. Inform your operator if repairs are necessary
Operation is not possible despite proper power supply	<ul style="list-style-type: none"> Control unit has shut down due to overheating The control unit has detected a fault and for safety reasons has locked the adjusting functions Control unit defective Handset faulty Drive connecting cable defective 	<ul style="list-style-type: none"> Observe max. duty cycle: Intermittent duty 2 min ON/18 min OFF; replace the control unit. Perform RESET (see Part B: Control unit – Reset » 62) Replace the control unit. Inform your operator if repairs are necessary Replace the handset with a new one Replace connecting cable
Manual CPR release of backrest (optional accessory) is not possible	<ul style="list-style-type: none"> Bowden cable is too loose or not attached Bowden cable is kinked 	<ul style="list-style-type: none"> Readjust at the release lever or attach properly Install new Bowden cable. Inform your operator if repairs are necessary
drive runs for a brief time only, then stops	<ul style="list-style-type: none"> Drive overloaded Structural obstructions in the way of bed adjustment 	<ul style="list-style-type: none"> Remove the overload in the bed, retest Remove obstructions; move bed away from obstructions (e.g. window sills, slanting ceilings)
Control partly not functioning	<ul style="list-style-type: none"> One or more motors are not connected properly/ electrical plug connections have come loose There is a serious problem with the control unit For safety reasons, all functions are locked 	<ul style="list-style-type: none"> Check electrical connection of all motors/ plug connections; Back rest, thigh rest and lift all function independently

Problem	Possible causes	Solution
		<p>Example: If only the lift is defective, it is still possible to move the back rest and thigh rest.</p> <ul style="list-style-type: none"> • Perform RESET (see Part B: Control unit – Reset » 62); if it occurs again: have drive system checked. Inform your operator if repairs are necessary
<p>Height adjustments and tilting not possible or only in one direction; signal tone sounds during adjustment</p>	<ul style="list-style-type: none"> • Control unit has “forgotten” the drive positions • Connecting cable defective 	<ul style="list-style-type: none"> • Perform initialisation; see Part B: Initialising the control unit » 60 • Replace connecting cable
<p>Height adjustment and tilting do not work; signal tone sounds during adjustment</p>	<ul style="list-style-type: none"> • Drive(s) defective • Connecting cable defective 	<ul style="list-style-type: none"> • Perform RESET (see Part B: Control unit – Reset » 62); then test each function independently to find out which drive is defective • Replace connecting cable

5 Maintenance

As well as the extensive routine inspections performed by technical personnel, the bed must also be checked at shorter regular intervals by non-technical users (care staff, family carers etc.), and be briefly visually inspected and have its functions tested before being occupied by a new user.

WARNING

Risk of injury

Failure to heed this warning may result in physical injury due to defective components.

- If you suspect that it is damaged or defective, take the bed out of service immediately and disconnect it from the mains supply until the defective pieces are replaced or repaired!
- Contact the operator who is responsible for you if the defective parts need to be replaced or repaired.

 All “serious incidents” ¹ that occurred in relation to the product must be notified to the manufacturer and the competent authorities in the member state in which the user and/or the resident resides (in Germany: www.BfArM.de). In other countries outside Germany or the EU, the relevant national regulations must be complied with!

¹: Incident that had, could have had, or could have, one of the following direct or indirect consequences: a) death of a patient, user or another person, b) temporary or permanent serious deterioration of the health of a patient, user or another person, c) serious risk for public health, (source: MDR (Medical Device Regulation), Art. 2(65)).

 Recommendation: Inspect all electrical and mechanical components once a month. In addition to the above, check the mains cable and handset every time they have been subjected to mechanical stress and after the bed has been moved. Use the following checklist to help you:

Check	OK	Not OK	Description of Fault
Visual inspection of the electrical components			
Handset, handset cable			Damage, routing of cable
Handset			Damage, foil

Check		OK	Not OK	Description of Fault
Switch mode power supply	Damage, no rattling noises when shaken, cable laying			
Visual inspection of the mechanical components				
Lifting pole, handle, adapter sleeves	Damage, deformation			
Bed frame	Damage, deformation			
Sprung slats	Damage, splinters			
Wooden surround	Damage, splinters			
Mattress base frame	Damage, deformation			
Safety side bars	Damage, splinters			
Locking levers of TSG, headboard, footboard, side panels	Clamping function			
Functional check of the electrical components				
Handset	Function test, locking function			
Functional check of the mechanical components				
Emergency release of the backrest	Test according to instruction manual			
Castors	Moving and braking			
Screws and bolts	Fixed securely			
Safety sides	Safe locking, unlocking			
Motor bolt	Fixed securely			
Lower leg rest	Engages properly			
Accessories (e.g. patient lifting pole, triangular handle)	Fastening, damage			

Check		OK	Not OK	Description of Fault
Inspector's signature:	Inspection result:			Date:

6 Cleaning and Disinfection

6.1 Cleaning - Private Use

ATTENTION

Material damage

Failure to heed this warning may result in material damage due to penetrating moisture.

- Unplug the power cable and store the power plug so that it does not come into excessive contact with water or other cleaning solutions (place in a plastic bag).
- Make sure that all plugs are properly inserted in the drive motors.
- Ensure that none of the electrical components show any signs of external damage; otherwise water or cleaning agents may penetrate the system. This can result in malfunctions or damage to the electrical components.
- The electrical components must not be cleaned with a water jet, a high pressure cleaner or any other similar device! Clean only with a moist cloth!
- If you suspect that water or any other form of moisture has penetrated into the electrical components, unplug the power pack immediately and do not plug it back into the socket. Label the bed clearly as “Out of Order” and take it out of service. Have it inspected by a qualified electrician.
- Failure to follow these safety instructions could result in considerable damage to the bed and its electrical equipment and lead to subsequent malfunctions!

6.2 Cleaning agents and disinfectants

Observe the following recommendations to ensure the bed remains fit for use for as long as possible:

- Do not use scouring agents, stainless steel care products, abrasive cleaning products or scouring pads. These products can damage the surface.
- We recommend cleaning the bed by wiping it with a (damp) cloth. When selecting a suitable detergent, ensure that it is mild (gentle to skin and surfaces) and environmentally friendly. A standard household cleaning agent and disinfectant can generally be used.
- Ensure that no liquid residues remain on any parts of the bed after cleaning or disinfection. Otherwise the surfaces in these areas may become damaged in the long term.
- It is essential to follow the manufacturer's dosage advice for cleaning agents and disinfectants to prevent damaging the plastic and painted or metal surfaces! It is not permitted to clean the bed using a manually operated steel jet nozzle which is, for example, connected to a steam cleaner/high pressure cleaner. A minimum distance of 30 cm from the electrical components cannot be guaranteed in this case.
- If, despite its excellent mechanical resistance, the coated surface is damaged by scratches or marks which permeate the entire coating, the affected areas should be resealed using a suitable repair substance to prevent moisture from penetrating. For further information, consult BURMEIER or a specialist dealer of your choice.
- Disinfectants based on compounds that could potentially release chlorine may be corrosive for metals, synthetics, rubbers and other materials over longer contact periods or when concentrations are too high. Use these agents sparingly and only if expressly required.

For disinfection by wiping, most cleaning and disinfection agents commonly used in institutions or care facilities, such as cold and hot water, detergents, alkaline solutions and alcohols, can be used.

These agents must not contain any substances that could change the surface structure or the adhesive properties of the plastic materials.

The choice of cleaning agents and disinfectants available on the market may change from time to time. Burmeier therefore routinely tests the most commonly used materials for compatibility. The most up-to-date list of tested cleaning agents and disinfectants can be obtained on request.

Our customer service centre in Germany:

Burmeier GmbH & Co. KG

(A Stieglmeyer-Group company)

Industriestraße 53 / 32120 Hiddenhausen / Germany

Tel.: +49 (0) 5223 9769 - 0

Fax: +49 (0) 5223 9769 - 090

Email: info@burmeier.com

Internet: www.burmeier.com

Customers outside Germany can contact our distribution companies in their particular country if they have any questions. Contact details can be found on our website.



Burmeier GmbH & Co. KG

Industriestraße 53 / D-32120 Hiddenhausen

Telephone: +49 (0) 5223 9769 - 0 / Fax: +49 (0) 5223 9769 - 090

E-mail: info@burmeier.com

www.burmeier.de

